



ELECTRIC TORQUE WRENCH ETWC SERIES

Tools for every conceivable need.....



www.powermasteramerica.com

ELECTRO ETWC SERIES

ELECTRIC TORQUE WRENCHES (WITH CONTROL PANEL)

Torque Range 150 Nm to 4200 Nm (110 Lb.ft - 3097 Lb.ft)

The **ETWC Series Torque Wrench** is a hand held, non-impacting electrically driven power tool designed to apply higher torque values. The tool is designed to deliver a preset torque load. Efficient, safe, and fast operation makes it suitable for heavy duty bolting applications.

The **Control Panel** is an integral part of the ETWC model and is used to set / adjust the torque values as per requirement.

The drive is connected to the control panel. As per the model and the application, the user can set the torque values in the increment of one. Only once the torque is confirmed by the user, the drive receives a signal to apply the set torque with the user pressing the trigger. The box contains a power cable, a socket to connect the drive, and a switch to shut off the power supply in an emergency.

Heavy Duty gear assembly train with precision gear tooth profile for smooth, reliable and accurate operation.

Shifter for forward/Reverse Driver.

Single trigger for Operating the tool.

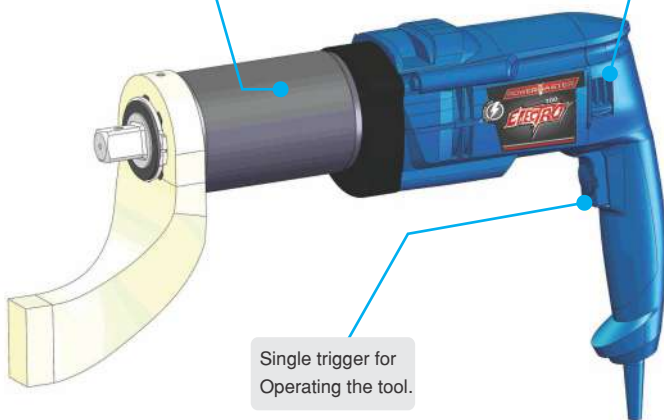

Technical Specification

Model No.	Min. Torque		Max. Torque		Free Speed rpm	Square Size		Weight with Reaction Arm Kg.
	Lb.ft	Nm	Lb.ft	Nm		inch		
ETWC - 50	110	150	479	650	25	3/4	6.8	
ETWC - 100	221	300	1106	1500	9	1	7.3	
ETWC - 200	553	750	2212	3000	4.5	1	9.8	
ETWC - 300	811	1100	3097	4200	1.7	1.1/2	12.6	

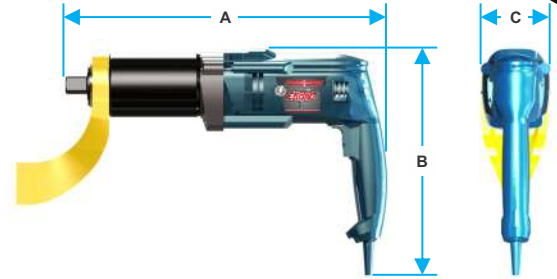

Model No.	A (mm)	B (mm)	C (mm)
ETWC - 15	377	205	85
ETWC - 100	394	205	85
ETWC - 200	445	215	90
ETWC - 300	465	215	90

Pre-Usage Checks

- The ETWC Controller requires single phase 230V AC ~.
- The single phase line must be electrically symmetrical with respect to Earth Ground.
- Extension cord quality and condition is important to ensure personal safety and ETWC performance.

Features

- 1 EASE OF OPERATION** - The wrench stops after the set torque values are achieved.
- 2 SMOOTH OPERATION** - The wrench is designed for smooth running without any impact.
- 3 WIDE RANGE** - Wide range of torque power from 150 Nm. to 4200 Nm. covered in four models.
- 4 ACCURATE AND CONVENIENT** - Light weight, ergonomically designed tool and electronically controlled cut-off system ensure repeatability of torque value.
- 5 HIGH PERFORMANCE GEARBOX** - High performance alloy steel gears with impact free loading ensure long life and high accuracy performance.
- 6 SINGLE PHASE SUPPLY** - Power required for the tool is readily available, single phase 230V - 50Hz.



▼ ETWC-50 is a safe and accurate torquing application.

Sr. No.	Part Description
A	7 Segment Display
B	Set Button
C	OK / RUN Button
D	Torque Unit Led (Nm)
E	Trip Led
F	Torque Increase Button
G	Torque Decrease Button



Salient Features

- 7 Segment display for ease of read.
- Heavy duty power cable.

ACCESSORIES

WHEEL EXTENSION

Wheel extensions are used to reach the wheel hub bolts and nuts, where fitment of the tool is not feasible.

POWERMASTER has a complete range of wheel extensions as referred below:

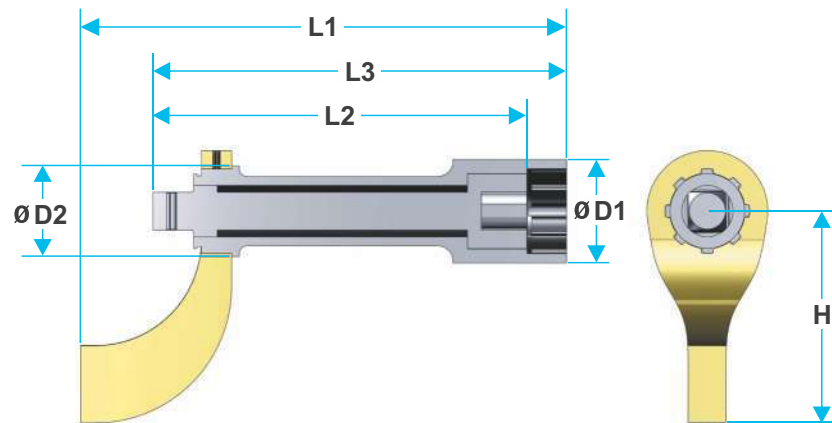

Technical Specification

Model No.	Sq. Drive	L1	L2	L3	D1	D2	H
	inch	mm	mm	mm	mm	mm	mm
PE 1206	3/4	210	150	185	70	45	142
PE 1208	3/4	260	200	235	70	45	142
PE 1210	3/4	310	250	285	70	45	142
PE 1608	1	265	200	235	70	52	142
PE 1610	1	315	250	285	70	52	142
PE 1608H	1	265	200	235	90	60	168

REACTION ARM

Different types of reaction arms are available for a variety of applications. Customized reaction arms are available on request.



Blank Reaction



Double End Blank



Standard Reaction



Deep Reaction



POWERMASTER AMERICA LLC.

26, Russell Park Road, Syosset, New York 11791.

Phone: +1 516.503.5294

Website: www.powermasteramerica.com email: sales@powermasteramerica.com