



## IMPACT SOCKETS & SLUGGING WRENCHES



## IMPACT SOCKETS, ACCESSORIES AND SOCKET SETS

- \* Standard, Deep and Thinwall Sockets
- \* Up to 3.1/2" square drive Impact Sockets through to 235MM (9.1/8") across the flats
- \* # 5 spline drive to **80mm (4")** across the flats
- \* Wide variety of Accessories

### Freecorner PROFILE

The **Freecorner** profile is provided on the square drives as well as on the hexagon end of Impact Sockets 1/2" square drive and above.

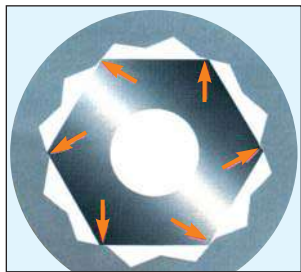

#### CONVENTIONAL PROFILE

Corner point contact high stress areas

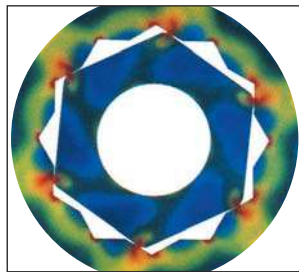

Highlights show contact points on the corner of the fastener

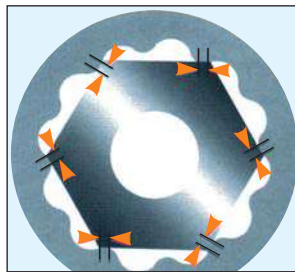

#### FREECORNER PROFILE

Distributed surface loads relieves possible stress area

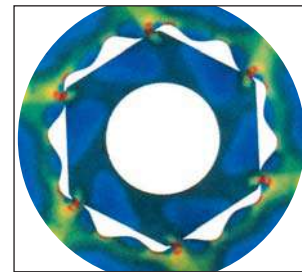

Highlights show contact points away from the corner of the fastener

The benefits of the **Freecorner** profile include are

- Reduced risk of fastener rounding.
- Increased chances of turning worn fasteners.
- Elimination of high stress concentration points increasing the impact resistance and the torque transmitting capability.

### 'POWERMASTER AMERICA' IMPACT SOCKETS

'POWERMASTER AMERICA' Impact Sockets of 1/2" square drive and above feature **freecorner** for flats above 17 mm (5/8").

- All Impact Sockets are made from high strength alloy steel.
- All Impact Sockets are heat treated for the best combination of strength and impact resistance.
- All Impact Sockets have an optimum wall thickness for strength and access on fasteners having restrictions.
- The depth of the Hex openings is designed to accommodate the full standard fastener head.
- All Impact Sockets have chamfered openings for ease in engagement with the drive tool and the fastener.
- Concentric openings and large clearance holes to meet industrial specifications.
- All Impact Sockets have a Ring-N-Pin arrangement for securing them to the drive.
- Sockets are plated and black oxidized coated for increased protection from rusting.

#### SAFETY NOTICE

Sockets in this catalog are designed for impact use. Always use safety goggles when using impact equipment.



<b>3/8" SQUARE DRIVE IMPACT SOCKETS</b>	<b>PAGE 4</b>	
<b>1/2" SQUARE DRIVE IMPACT SOCKETS</b>	<b>PAGE 6</b>	
<b>3/4" SQUARE DRIVE IMPACT SOCKETS</b>	<b>PAGE 9</b>	
<b>1" SQUARE DRIVE IMPACT SOCKETS</b>	<b>PAGE 13</b>	
<b>1.1/2" SQUARE DRIVE IMPACT SOCKETS</b>	<b>PAGE 19</b>	
<b>2.1/2" SQUARE DRIVE IMPACT SOCKETS</b>	<b>PAGE 22</b>	
<b>3.1/2" SQUARE DRIVE IMPACT SOCKETS</b>	<b>PAGE 25</b>	
<b># 5 SPLINE DRIVE IMPACT SOCKETS</b>	<b>PAGE 26</b>	
<b>CASTELLATED SOCKETS</b>	<b>PAGE 29</b>	
<b>STRAIGHT SLUGGING WRENCHES METRIC &amp; SAE</b>	<b>PAGE 31</b>	
<b>OFFSET SLUGGING WRENCHES METRIC &amp; SAE</b>	<b>PAGE 33</b>	
<b>OPEN JAW SLUGGING WRENCHES</b>	<b>PAGE 34</b>	
<b>BOX BI-HEX SLUGGING WRENCHES</b>	<b>PAGE 35</b>	
<b>STRUCTURAL WRENCHES</b>	<b>PAGE 36</b>	
<b>INSERT SOCKETS</b>	<b>PAGE 38</b>	
<b>TURBINE TOOLS</b>	<b>PAGE 39</b>	

### POWERMASTER AMERICA WARRANTY

The Powermaster America warranty will replace free to the original purchaser any qualifying socket found to be defective in either material or workmanship, indicated by premature wear or breakage. Determination of free replacement will be done by your Powermaster America distributor. Impact Sockets, by nature of their application are subject to extreme stresses, therefore special application sockets such as thinwall, hex driver, accessories and slugging wrenches are specifically excluded from the replacement warranty.



3/8"

IMPACT SOCKETS

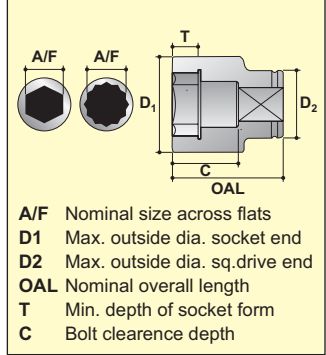

METRIC HEXAGON



FRACTIONAL HEXAGON



A/F mm	MODEL NO.	D1 mm	D2 mm	T mm	C mm	OAL mm	Wt. Kg.
8	S-06M8	14.0	19.0	6.0	14.0	25.5	0.030
9	S-06M9	15.0	19.0	7.0	14.0	25.5	0.031
10	S-06M10	16.0	19.0	7.0	14.0	25.5	0.032
11	S-06M11	17.0	19.0	8.0	14.0	25.5	0.033
12	S-06M12	19.0	19.0	9.0	14.0	25.5	0.036
13	S-06M13	20.0	20.0	9.0	14.0	25.5	0.041
14	S-06M14	21.0	21.0	10.0	18.0	30.0	0.053
15	S-06M15	22.0	22.0	10.0	18.0	30.0	0.059
16	S-06M16	24.0	22.0	10.0	18.0	30.0	0.066
17	S-06M17	25.0	22.0	12.0	18.0	30.0	0.072
18	S-06M18	26.0	22.0	12.0	18.0	30.0	0.077
19	S-06M19	27.0	22.0	12.0	18.0	30.0	0.082
20	S-06M20	29.0	22.0	12.0	18.0	30.0	0.094
21	S-06M21	30.0	22.0	12.0	18.0	30.0	0.099
22	S-06M22	31.0	22.0	13.0	18.0	30.0	0.106

A/F inch	MODEL NO.	D1 inch	D2 inch	T inch	C inch	OAL inch	Wt. lbs.
5/16	S-0605	0.550	0.747	0.236	0.530	1.002	0.067
3/8	S-0606	0.629	0.747	0.275	0.530	1.002	0.070
7/16	S-0607	0.668	0.747	0.314	0.530	1.002	0.072
1/2	S-0608	0.786	0.786	0.354	0.530	1.002	0.089
9/16	S-0609	0.864	0.864	0.393	0.707	1.179	0.130
5/8	S-0610	0.943	0.864	0.393	0.707	1.179	0.144
11/16	S-0611	1.022	0.864	0.472	0.707	1.179	0.168
3/4	S-0612	1.061	0.864	0.472	0.707	1.179	0.181
13/16	S-0613	1.179	0.864	0.472	0.707	1.179	0.218
7/8	S-0614	1.218	0.864	0.511	0.707	1.179	0.233

METRIC DEEP HEXAGON



FRACTIONAL DEEP HEXAGON



A/F mm	MODEL NO.	D1 mm	D2 mm	T mm	C mm	OAL mm	Wt. Kg.
8	S-06M8L	14.0	19.0	6.0	42.0	54.0	0.055
9	S-06M9L	15.0	19.0	7.0	42.0	54.0	0.058
10	S-06M10L	16.0	19.0	7.0	42.0	54.0	0.062
11	S-06M11L	17.0	19.0	8.0	42.0	54.0	0.064
12	S-06M12L	19.0	19.0	9.0	42.0	54.0	0.076
13	S-06M13L	20.0	20.0	9.0	42.0	54.0	0.084
14	S-06M14L	21.0	21.0	10.0	48.0	60.0	0.101
15	S-06M15L	22.0	22.0	10.0	48.0	60.0	0.110
17	S-06M17L	25.0	22.0	12.0	48.0	60.0	0.139
19	S-06M19L	27.0	22.0	12.0	48.0	60.0	0.154

A/F inch	MODEL NO.	D1 inch	D2 inch	T inch	C inch	OAL inch	Wt. lbs.
5/16	S-0605L	0.550	0.747	0.236	1.650	2.122	0.122
3/8	S-0606L	0.629	0.747	0.275	1.650	2.122	0.135
7/16	S-0607L	0.668	0.747	0.314	1.650	2.122	0.141
1/2	S-0608L	0.786	0.786	0.354	1.650	2.122	0.184
9/16	S-0609L	0.864	0.864	0.393	1.886	2.358	0.243
5/8	S-0610L	0.944	0.866	0.433	1.811	2.362	0.265
11/16	S-0611L	1.179	0.866	0.472	2.047	2.598	0.365
3/4	S-0612L	1.061	0.864	0.472	1.886	2.358	0.339
13/16	S-0613L	1.179	0.864	0.472	2.122	2.593	0.334
7/8	S-0614L	1.218	0.864	0.511	2.122	2.593	0.348

METRIC BIHEXAGON



FRACTIONAL BIHEXAGON



A/F mm	MODEL NO.	D1 mm	D2 mm	T mm	C mm	OAL mm	Wt. Kg.
8	06M8DH	14.0	19.0	6.0	14.0	25.5	0.030
9	06M9DH	15.0	19.0	7.0	14.0	25.5	0.031
10	06M10DH	16.0	19.0	7.0	14.0	25.5	0.032
11	06M11DH	17.0	19.0	8.0	14.0	25.5	0.033
12	06M12DH	19.0	19.0	9.0	14.0	25.5	0.036
13	06M13DH	20.0	20.0	9.0	14.0	25.5	0.041
14	06M14DH	21.0	21.0	10.0	18.0	30.0	0.053
15	06M15DH	22.0	22.0	10.0	18.0	30.0	0.059
16	06M16DH	24.0	22.0	10.0	18.0	30.0	0.066
17	06M17DH	25.0	22.0	12.0	18.0	30.0	0.072
18	06M18DH	26.0	22.0	12.0	18.0	30.0	0.077
19	06M19DH	27.0	22.0	12.0	18.0	30.0	0.082
20	06M20DH	29.0	22.0	12.0	18.0	30.0	0.094
21	06M21DH	30.0	22.0	12.0	18.0	30.0	0.099
22	06M22DH	31.0	22.0	13.0	18.0	30.0	0.106

A/F inch	MODEL NO.	D1 inch	D2 inch	T inch	C inch	OAL inch	Wt. lbs.
3/8	0606DH	0.629	0.747	0.275	0.530	1.002	0.070
7/16	0607DH	0.668	0.747	0.314	0.530	1.002	0.072
1/2	0608DH	0.786	0.786	0.354	0.530	1.002	0.089
9/16	0609DH	0.864	0.864	0.393	0.707	1.179	0.130
5/8	0610DH	0.943	0.864	0.393	0.707	1.179	0.144
11/16	0611DH	1.022	0.864	0.472	0.707	1.179	0.168
3/4	0612DH	1.061	0.864	0.472	0.707	1.179	0.181
13/16	0613DH	1.179	0.864	0.472	0.707	1.179	0.218
7/8	0614DH	1.218	0.864	0.511	0.707	1.179	0.233



# IMPACT SOCKETS THINWALL

3/8"

## METRIC HEXAGON



A/F mm	MODEL NO.	D1 mm	D2 mm	T mm	C mm	OAL mm	Wt. Kg.
8	S-06M8T	12.3	19.0	6.0	14.0	25.5	0.028
10	S-06M10T	14.8	19.0	7.0	14.0	25.5	0.030
11	S-06M11T	16.1	19.0	8.0	14.0	25.5	0.031
13	S-06M13T	18.6	19.0	9.0	14.0	25.5	0.035
17	S-06M17T	23.7	22.0	12.0	18.0	30.0	0.069
19	S-06M19T	26.3	22.0	12.0	18.0	30.0	0.081

## FRACTIONAL HEXAGON



A/F inch	MODEL NO.	D1 inch	D2 inch	T inch	C inch	OAL inch	Wt. lbs.
5/16	S-0605T	0.484	0.748	0.236	0.531	1.004	0.061
3/8	S-0606T	0.551	0.748	0.236	0.531	1.004	0.065
7/16	S-0607T	0.634	0.748	0.315	0.531	1.004	0.068
1/2	S-0608T	0.732	0.748	0.354	0.531	1.004	0.077
9/16	S-0609T	0.787	0.787	0.394	0.531	1.004	0.088
5/8	S-0610T	0.866	0.866	0.394	0.709	1.181	0.138

Thinwall Deep Hexagon Sockets available on request.

# IMPACT ACCESSORIES

## METRIC HEX DRIVER SOCKETS

HEX A/F MM	MODEL NO.	BIT LENGTH	OAL mm	Wt. Kg.
4	06M04H	15.0	45.0	0.035
5	06M05H	15.0	45.0	0.035
6	06M06H	15.0	45.0	0.035
8	06M08H	15.0	45.0	0.045
10	06M10H	15.0	45.0	0.050

## FRACTIONAL HEX DRIVER SOCKETS

HEX A/F SAE	MODEL NO.	BIT LENGTH	OAL inch	Wt. lbs.
5/32	06005H	0.590	1.771	0.080
3/16	0603H	0.590	1.771	0.080
7/32	06007H	0.590	1.771	0.080
1/4	0604H	0.590	1.771	0.080
5/16	0605H	0.590	1.771	0.090
3/8	0606H	0.590	1.771	0.110

## REGULAR EXTENSIONS

OAL mm	MODEL NO.	SHANK DIA mm (inch)	HEAD DIA mm (inch)	Wt. Kg. (lbs.)
75 (3")	E0603	13.0 (0.511)	22.0 (0.866)	0.09 (0.20)
150 (6")	E0606			0.16 (0.35)
300 (12")	E0612			0.35 (0.77)



## SQUARE ADAPTORS

SIZE	MODEL NO.	HEAD DIA mm (inch)	OAL mm (inch)	Wt. Kg. (lbs.)
3/8" F X 1/2" M	A0608	22.0 (0.866)	35.0 (1.377)	0.07 (0.15)
3/8" F X 1/4" M	A0606		32.0 (1.259)	0.05 (0.11)



## UNIVERSAL JOINT

SQUARE DRIVE	MODEL NO.	DIA mm (inch)	OAL mm (inch)	Wt. Kg. (lbs.)
3/8"	U0606	22.0 (0.866)	52.0 (2.047)	0.12 (0.27)



## DOUBLE MALE EXTENSIONS

OAL mm	MODEL NO.	SHANK DIA mm (inch)	HEAD DIA mm (inch)	Wt. Kg. (lbs.)
75 (3")	S0603	13.0 (0.511)	9.3 (0.366)	0.06 (0.13)
125 (5")	S0605			0.12 (0.26)
250 (10")	S0610			0.30 (0.66)



## DOUBLE FEMALE ADAPTORS

SIZE	MODEL NO.	HEAD DIA mm (inch)	OAL mm (inch)	Wt. Kg. (lbs.)
3/8" F X 1/2" F	AN0608	22.0 (0.866)	38.0 (1.496)	0.09 (0.20)
3/8" F X 3/8" F	AN0606		35.0 (1.377)	0.07 (0.15)



1/2"

# IMPACT SOCKETS

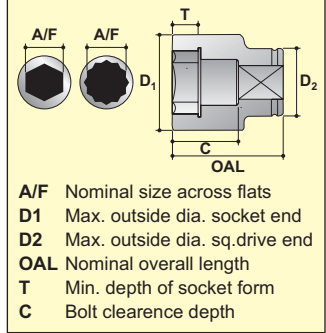

## METRIC HEXAGON



A/F mm	MODEL NO.	D1 mm	D2 mm	T mm	C mm	OAL mm	Wt. Kg.
8	S-08M8	15.0	25.0	6.0	15.0	32.0	0.060
9	S-08M9	16.0	25.0	7.0	15.0	32.0	0.060
10	S-08M10	17.0	25.0	8.0	15.0	32.0	0.060
11	S-08M11	19.0	25.0	9.0	17.0	34.0	0.067
12	S-08M12	20.0	25.0	9.0	17.0	34.0	0.069
13	S-08M13	21.0	25.0	10.0	18.0	35.0	0.073
14	S-08M14	22.0	25.0	10.0	18.0	35.0	0.076
15	S-08M15	24.0	25.0	11.0	18.0	35.0	0.082
16	S-08M16	25.0	25.0	11.0	18.0	35.0	0.085
17	S-08M17	26.0	26.0	12.0	20.0	37.0	0.099
18	S-08M18	27.0	27.0	13.0	20.0	37.0	0.109
19	S-08M19	29.0	29.0	14.0	22.0	39.0	0.137
21	S-08M21	31.0	30.0	14.0	22.0	39.0	0.155
22	S-08M22	32.0	30.0	14.0	22.0	39.0	0.162
23	S-08M23	34.0	30.0	15.0	25.0	42.0	0.192
24	S-08M24	35.0	30.0	15.0	25.0	42.0	0.200
25	S-08M25	36.0	30.0	16.0	26.0	43.0	0.211
26	S-08M26	37.0	30.0	16.0	26.0	43.0	0.218
27	S-08M27	39.0	30.0	16.0	26.0	43.0	0.236
28	S-08M28	40.0	30.0	17.0	27.0	44.0	0.250
30	S-08M30	42.0	30.0	17.0	27.0	44.0	0.261
32	S-08M32	45.0	44.0	18.0	28.0	45.0	0.415
36	S-08M36	50.0	44.0	20.0	30.0	47.0	0.495

## FRACTIONAL HEXAGON



A/F inch	MODEL NO.	D1 inch	D2 inch	T inch	C inch	OAL inch	Wt. lbs.
3/8	S-0806	0.669	0.984	0.315	0.591	1.260	0.132
7/16	S-0807	0.748	0.984	0.354	0.669	1.339	0.148
1/2	S-0808	0.827	0.984	0.394	0.709	1.378	0.160
9/16	S-0809	0.945	0.984	0.433	0.709	1.378	0.181
5/8	S-0810	0.984	0.984	0.433	0.709	1.378	0.188
11/16	S-0811	1.063	1.063	0.512	0.787	1.457	0.240
3/4	S-0812	1.142	1.142	0.551	0.866	1.535	0.301
13/16	S-0813	1.220	1.181	0.551	0.866	1.535	0.341
7/8	S-0814	1.339	1.181	0.591	0.984	1.654	0.423
15/16	S-0815	1.378	1.181	0.591	0.984	1.654	0.440
1	S-0816	1.457	1.181	0.630	1.024	1.693	0.480
1.1/16	S-0817	1.535	1.181	0.630	1.024	1.693	0.519
1.1/8	S-0818	1.654	1.181	0.669	1.063	1.732	0.575
1.3/16	S-0819	1.672	1.732	0.709	1.102	1.772	0.813
1.1/4	S-0820	1.772	1.732	0.709	1.102	1.772	0.963
1.5/16	S-0821	1.862	1.732	0.709	1.102	1.772	1.083
1.3/8	S-0822	1.869	1.732	0.787	1.181	1.850	1.088
1.7/16	S-0823	1.968	1.732	0.866	1.220	1.889	1.210
1.1/2	S-0824	2.086	1.732	0.866	1.338	2.007	1.255

## METRIC DEEP HEXAGON



A/F mm	MODEL NO.	D1 mm	D2 mm	T mm	C mm	OAL mm	Wt. Kg.
8	S-08M8L	15.0	25.0	6.0	63.0	80.0	0.112
9	S-08M9L	16.0	25.0	7.0	63.0	80.0	0.117
10	S-08M10L	17.0	25.0	8.0	63.0	80.0	0.122
11	S-08M11L	19.0	25.0	9.0	63.0	80.0	0.142
12	S-08M12L	20.0	25.0	9.0	63.0	80.0	0.149
13	S-08M13L	21.0	25.0	10.0	63.0	80.0	0.156
14	S-08M14L	22.0	25.0	10.0	63.0	80.0	0.160
15	S-08M15L	24.0	25.0	11.0	63.0	80.0	0.184
16	S-08M16L	25.0	25.0	11.0	63.0	80.0	0.192
17	S-08M17L	26.0	26.0	12.0	63.0	80.0	0.207
18	S-08M18L	27.0	27.0	13.0	63.0	80.0	0.222
19	S-08M19L	29.0	29.0	14.0	63.0	80.0	0.264
21	S-08M21L	31.0	30.0	14.0	63.0	80.0	0.297
22	S-08M22L	32.0	30.0	14.0	68.0	85.0	0.333
23	S-08M23L	34.0	30.0	15.0	68.0	85.0	0.375
24	S-08M24L	35.0	30.0	15.0	68.0	85.0	0.389
25	S-08M25L	36.0	30.0	16.0	68.0	85.0	0.403
26	S-08M26L	37.0	30.0	16.0	68.0	85.0	0.415
27	S-08M27L	39.0	30.0	16.0	68.0	85.0	0.459
28	S-08M28L	40.0	30.0	17.0	68.0	85.0	0.476
30	S-08M30L	42.0	30.0	17.0	68.0	85.0	0.501
32	S-08M32L	45.0	44.0	18.0	68.0	85.0	0.684
36	S-08M36L	50.0	44.0	20.0	68.0	85.0	0.799

## FRACTIONAL DEEP HEXAGON



A/F inch	MODEL NO.	D1 inch	D2 inch	T inch	C inch	OAL inch	Wt. lbs.
3/8	S-0806L	0.669	0.984	0.315	2.480	3.150	0.270
7/16	S-0807L	0.748	0.984	0.354	2.480	3.150	0.310
1/2	S-0808L	0.827	0.984	0.394	2.480	3.150	0.340
9/16	S-0809L	0.945	0.984	0.433	2.480	3.150	0.400
5/8	S-0810L	0.984	0.984	0.433	2.480	3.150	0.420
11/16	S-0811L	1.063	1.063	0.512	2.480	3.150	0.490
3/4	S-0812L	1.142	1.142	0.551	2.480	3.150	0.580
13/16	S-0813L	1.220	1.181	0.551	2.480	3.150	0.650
7/8	S-0814L	1.339	1.181	0.591	2.677	3.346	0.830
15/16	S-0815L	1.378	1.181	0.591	2.677	3.346	0.860
1	S-0816L	1.457	1.181	0.630	2.677	3.346	0.910
1.1/16	S-0817L	1.535	1.181	0.630	2.677	3.346	1.010
1.1/8	S-0818L	1.654	1.181	0.669	2.677	3.346	1.100
1.3/16	S-0819L	1.672	1.732	0.709	2.677	3.346	1.500
1.1/4	S-0820L	1.772	1.732	0.709	2.677	3.346	1.500
1.5/16	S-0821L	1.819	1.682	0.787	2.677	3.346	1.560
1.3/8	S-0822L	1.869	1.732	0.787	2.677	3.346	1.760
1.7/16	S-0823L	1.968	1.732	0.866	2.676	3.346	1.870
1.1/2	S-0824L	2.029	1.732	0.866	2.676	3.346	1.910

# IMPACT SOCKETS SETS

1/2"



## METRIC SIZE

MODEL NO.	QTY.	SOCKET A/F
S-08M51	13 PIECES	8,9,10,11,12,13,14,15,16,17,18,19,21
S-08M52	16 PIECES	10,11,12,13,14,15,16,17,18,19,20,21,22,23,24,27
S-08M53	6 PIECES	13,14,15,16,17,18
S-08LM51	16 PIECES DEEP	10,11,12,13,14,15,16,17,18,19,20,21,22,23,24,27
S-08LM52	12 PIECES DEEP	10,11,12,13,14,15,16,17,18,19,20,21



## FRACTIONAL SIZE

MODEL NO.	QTY.	SOCKET A/F
S-0851	11 PIECES + UJOINT	1/2,9/16,5/8,3/4,13/16,7/8,15/16,1,1.1/16,1.1/8,U-JOINT
S-0852	13 PIECES	7/16,1/2,9/16,5/8,11/16,3/4,13/16,7/8,15/16,1,1.1/16,1.1/8,1.3/4
S-0853	7 PIECES	7/16,1/2,9/16,5/8,11/16,3/4,13/16
S-08L51	14 PIECES DEEP	3/8,7/16,1/2,9/16,5/8,11/16,3/4,13/16,7/8,15/16,1,1.1/16,1.1/8,1.1/4
S-08L52	7 PIECES DEEP	7/16,1/2,9/16,5/8,11/16,3/4,13/16

# IMPACT SOCKETS



## METRIC BIHEXAGON



A/F mm	MODEL NO.	D1 mm	D2 mm	T mm	C mm	OAL mm	Wt. Kg.
8	08M8DH	15.0	25.0	6.0	15.0	32.0	0.060
9	08M9DH	16.0	25.0	7.0	15.0	32.0	0.060
10	08M10DH	17.0	25.0	8.0	15.0	32.0	0.060
11	08M11DH	19.0	25.0	9.0	17.0	34.0	0.067
12	08M12DH	20.0	25.0	9.0	17.0	34.0	0.069
13	08M13DH	21.0	25.0	10.0	18.0	35.0	0.073
14	08M14DH	22.0	25.0	10.0	18.0	35.0	0.076
15	08M15DH	24.0	25.0	11.0	18.0	35.0	0.082
16	08M16DH	25.0	25.0	11.0	18.0	35.0	0.085
17	08M17DH	26.0	26.0	12.0	20.0	37.0	0.099
18	08M18DH	27.0	27.0	13.0	20.0	37.0	0.109
19	08M19DH	29.0	29.0	14.0	22.0	39.0	0.137
21	08M21DH	31.0	30.0	14.0	22.0	39.0	0.155
22	08M22DH	32.0	30.0	14.0	22.0	39.0	0.162
23	08M23DH	34.0	30.0	15.0	25.0	42.0	0.192
24	08M24DH	35.0	30.0	15.0	25.0	42.0	0.200
25	08M25DH	36.0	30.0	16.0	26.0	43.0	0.211
26	08M26DH	37.0	30.0	16.0	26.0	43.0	0.218
27	08M27DH	39.0	30.0	16.0	26.0	43.0	0.236
28	08M28DH	40.0	30.0	17.0	27.0	44.0	0.250
30	08M30DH	42.0	30.0	17.0	27.0	44.0	0.261
32	08M32DH	45.0	44.0	18.0	28.0	45.0	0.415
36	08M36DH	50.0	44.0	20.0	30.0	47.0	0.495



## FRACTIONAL BIHEXAGON



A/F inch	MODEL NO.	D1 inch	D2 inch	T inch	C inch	OAL inch	Wt. lbs.
7/16	0807DH	0.748	0.984	0.354	0.669	1.339	0.148
1/2	0808DH	0.827	0.984	0.394	0.709	1.378	0.160
9/16	0809DH	0.945	0.984	0.433	0.709	1.378	0.181
5/8	0810DH	0.984	0.984	0.433	0.709	1.378	0.188
11/16	0811DH	1.063	1.063	0.512	0.787	1.457	0.240
3/4	0812DH	1.142	1.142	0.551	0.866	1.535	0.301
13/16	0813DH	1.220	1.181	0.551	0.866	1.535	0.341
7/8	0814DH	1.339	1.181	0.591	0.984	1.654	0.423
15/16	0815DH	1.378	1.181	0.591	0.984	1.654	0.440
1	0816DH	1.457	1.181	0.630	1.024	1.693	0.480
1.1/16	0817DH	1.535	1.181	0.630	1.024	1.693	0.519
1.1/8	0818DH	1.654	1.181	0.669	1.063	1.732	0.575
1.3/16	0819DH	1.672	1.732	0.709	1.102	1.772	0.813
1.1/4	0820DH	1.772	1.732	0.709	1.102	1.772	0.963
1.5/16	0821DH	1.862	1.732	0.709	1.102	1.772	1.083
1.3/8	0822DH	1.869	1.732	0.787	1.181	1.850	1.088
1.7/16	0823DH	1.968	1.732	0.866	1.220	1.889	1.210
1.1/2	0824DH	2.086	1.732	0.866	1.338	2.007	1.255

IMPACT SOCKETS 1/2"



# IMPACT SOCKETS

## METRIC HEXAGON



A/F mm	MODEL NO.	D1 mm	D2 mm	T mm	C mm	OAL mm	Wt. Kg.
15	S-08M15T	22.0	25.0	11.0	18.0	35.0	0.073
16	S-08M16T	23.3	25.0	11.0	18.0	35.0	0.078
17	S-08M17T	25.0	25.0	12.0	19.0	36.0	0.086
18	S-08M18T	26.0	26.0	13.0	20.0	37.0	0.097
19	S-08M19T	27.0	27.0	14.0	21.0	38.0	0.109
21	S-08M21T	29.5	30.0	14.0	22.0	39.0	0.137

## FRACTIONAL HEXAGON



A/F inch	MODEL NO.	D1 inch	D2 inch	T inch	C inch	OAL inch	Wt. lbs.
9/16	S-0809T	0.864	0.984	0.433	0.709	1.378	0.160
5/8	S-0810T	0.917	0.984	0.433	0.709	1.378	0.170
11/16	S-0811T	0.984	0.984	0.472	0.748	1.417	0.190
3/4	S-0812T	1.063	1.063	0.551	0.827	1.496	0.240
13/16	S-0813T	1.161	1.161	0.551	0.866	1.535	0.300
15/16	S-0815T	1.341	1.181	0.551	0.905	1.614	0.420

Thinwall Deep Hexagon Sockets available on request.

# IMPACT ACCESSORIES

## METRIC HEX DRIVER SOCKETS

HEX A/F mm	MODEL NO.	BIT LENGTH	OAL mm	Wt. Kg.
6	08M6H	15.0	50.0	0.080
8	08M8H	15.0	50.0	0.080
10	08M10H	18.0	55.0	0.090
12	08M12H	18.0	60.0	0.110
14	08M14H	25.0	60.0	0.125
17	08M17H	25.0	60.0	0.145

## FRACTIONAL HEX DRIVE SOCKETS

HEX A/F inch	MODEL NO.	BIT LENGTH	OAL inch	Wt. lbs.
1/4	0804H	0.590	1.968	0.160
5/16	0805H	0.590	1.968	0.175
3/8	0806H	0.708	2.165	0.190
7/16	0807H	0.708	2.362	0.200
1/2	0808H	0.708	2.362	0.255
9/16	0809H	0.984	2.362	0.255

## REGULAR EXTENSIONS

OAL mm (inch)	MODEL NO.	SHANK DIA mm (inch)	HEAD DIA mm (inch)	Wt. Kg. (lbs.)
75 (3")	E0803			0.20 (0.44)
125 (5")	E0805	20.0 (0.787)	30.0 (1.181)	0.27 (0.59)
200 (8")	E0810			0.38 (0.83)



## SQUARE ADAPTORS

SIZE	MODEL NO.	HEAD DIA mm (inch)	OAL mm (inch)	Wt. Kg. (lbs.)
1/2" F X 3/8" M	A0806	25.0 (0.984)	40.0 (1.574)	0.07 (0.15)
1/2" F X 3/4" M	A0812	30.0 (1.181)	50.0 (1.968)	0.12 (0.26)



## UNIVERSAL JOINT

SQUARE DRIVE	MODEL NO.	DIA mm (inch)	OAL mm (inch)	Wt. Kg. (lbs.)
1/2"	U0808	30.0 (1.181)	72.0 (2.834)	0.25 (0.55)



## DOUBLE MALE EXTENSIONS

OAL mm (inch)	MODEL NO.	SHANK DIA mm (inch)	HEAD DIA mm (inch)	Wt. Kg. (lbs.)
50 (2")	S0802			0.12 (0.26)
127 (5")	S0805	17.0 (0.669)	12.7 (0.500)	0.23 (0.50)



## DOUBLE FEMALE ADAPTORS

SIZE	MODEL NO.	HEAD DIA mm (inch)	OAL mm (inch)	Wt. Kg. (lbs.)
1/2" F X 1/2" F	AN0808	30.0 (1.181)	39.0 (1.534)	0.16 (0.35)
1/2" F X 3/4" F	AN0812		47.0 (1.850)	0.20 (0.44)





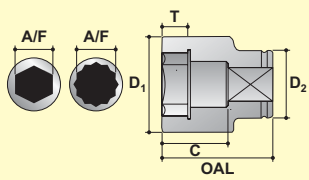

**A/F** Nominal size across flats  
**D1** Max. outside dia. socket end  
**D2** Max. outside dia. sq. drive end  
**OAL** Nominal overall length  
**T** Min. depth of socket form  
**C** Bolt clearance depth

# IMPACT SOCKETS

3/4"



## METRIC HEXAGON

A/F mm	MODEL NO.	D1 mm	D2 mm	T mm	C mm	OAL mm	Wt. Kg.
17	S-12M17	30.0	42.0	12.0	21.0	45.0	0.303
19	S-12M19	32.0	42.0	12.0	21.0	45.0	0.306
21	S-12M21	36.0	42.0	13.0	24.0	48.0	0.336
22	S-12M22	37.0	42.0	13.0	24.0	48.0	0.338
23	S-12M23	39.0	42.0	13.0	24.0	48.0	0.348
24	S-12M24	39.0	42.0	15.0	24.0	48.0	0.342
26	S-12M26	41.0	44.0	15.0	24.0	48.0	0.376
27	S-12M27	44.0	44.0	16.0	24.0	48.0	0.396
28	S-12M28	44.0	44.0	16.0	24.0	48.0	0.388
30	S-12M30	47.0	44.0	18.0	27.0	51.0	0.443
32	S-12M32	49.0	44.0	18.0	27.0	51.0	0.453
33	S-12M33	50.0	44.0	18.0	27.0	51.0	0.459
34	S-12M34	52.0	44.0	20.0	30.0	54.0	0.509
36	S-12M36	54.0	54.0	20.0	30.0	54.0	0.647
38	S-12M38	57.0	54.0	23.0	35.0	59.0	0.754
41	S-12M41	61.0	54.0	23.0	35.0	59.0	0.811
42	S-12M42	62.0	54.0	25.0	35.0	59.0	0.814
43	S-12M43	63.0	54.0	25.0	38.0	62.0	0.862
46	S-12M46	67.0	54.0	25.0	38.0	62.0	0.941
50	S-12M50	70.0	54.0	28.0	41.0	65.0	0.968

## FRACTIONAL HEXAGON

A/F inch	MODEL NO.	D1 inch	D2 inch	T inch	C inch	OAL inch	Wt. lbs.
9/16	S-1209	1.131	1.654	0.472	0.827	1.772	0.620
5/8	S-1210	1.181	1.654	0.472	0.827	1.772	0.670
11/16	S-1211	1.211	1.654	0.472	0.827	1.772	0.690
3/4	S-1212	1.260	1.654	0.472	0.827	1.772	0.670
13/16	S-1213	1.417	1.654	0.512	0.945	1.890	0.740
7/8	S-1214	1.535	1.654	0.512	0.945	1.890	0.770
15/16	S-1215	1.535	1.654	0.591	0.945	1.890	0.750
1	S-1216	1.614	1.732	0.591	0.945	1.890	0.830
1.1/16	S-1217	1.732	1.732	0.630	0.945	1.890	0.870
1.1/8	S-1218	1.850	1.732	0.709	1.063	2.008	0.970
1.3/16	S-1219	1.880	1.732	0.709	1.063	2.008	0.970
1.1/4	S-1220	1.929	1.732	0.709	1.063	2.008	1.000
1.5/16	S-1221	2.047	1.732	0.787	1.181	2.126	1.120
1.3/8	S-1222	2.076	2.126	0.787	1.181	2.126	1.400
1.7/16	S-1223	2.106	2.126	0.787	1.181	2.126	1.400
1.1/2	S-1224	2.344	2.126	0.906	1.378	2.323	1.660
1.9/16	S-1225	2.352	2.126	0.906	1.378	2.323	1.760
1.5/8	S-1226	2.441	2.126	0.984	1.378	2.323	1.790
1.11/16	S-1227	2.480	2.126	0.984	1.496	2.441	1.900
1.3/4	S-1228	2.688	2.126	0.984	1.496	2.441	2.070
1.13/16	S-1229	2.688	2.126	0.984	1.496	2.441	2.070
1.7/8	S-1230	2.706	2.126	1.102	1.614	2.559	2.130
2	S-1232	2.981	2.441	1.181	1.732	2.677	2.780

## METRIC DEEP HEXAGON

A/F mm	MODEL NO.	D1 mm	D2 mm	T mm	C mm	OAL mm	Wt. Kg.
17	S-12M17L	30.0	42.0	12.0	61.0	85.0	0.463
19	S-12M19L	32.0	42.0	12.0	61.0	85.0	0.479
21	S-12M21L	36.0	42.0	13.0	61.0	85.0	0.542
22	S-12M22L	37.0	42.0	13.0	61.0	85.0	0.551
23	S-12M23L	39.0	42.0	13.0	61.0	85.0	0.586
24	S-12M24L	40.0	42.0	15.0	61.0	85.0	0.595
26	S-12M26L	41.0	42.0	15.0	66.0	90.0	0.618
27	S-12M27L	43.0	43.0	16.0	66.0	90.0	0.674
28	S-12M28L	44.0	44.0	16.0	66.0	90.0	0.699
30	S-12M30L	47.0	44.0	18.0	66.0	90.0	0.769
32	S-12M32L	49.0	44.0	18.0	66.0	90.0	0.798
33	S-12M33L	50.0	44.0	18.0	66.0	90.0	0.812
34	S-12M34L	52.0	44.0	20.0	66.0	90.0	0.869
36	S-12M36L	54.0	54.0	20.0	66.0	90.0	1.034
38	S-12M38L	57.0	54.0	23.0	66.0	90.0	1.125
41	S-12M41L	61.0	54.0	23.0	66.0	90.0	1.229
42	S-12M42L	62.0	54.0	25.0	66.0	90.0	1.241
43	S-12M43L	63.0	54.0	25.0	66.0	90.0	1.255
46	S-12M46L	67.0	54.0	25.0	76.0	100.0	1.563
50	S-12M50L	70.0	54.0	28.0	76.0	100.0	1.573

## FRACTIONAL DEEP HEXAGON

A/F inch	MODEL NO.	D1 inch	D2 inch	T inch	C inch	OAL inch	Wt. lbs.
9/16	S-1209L	1.131	1.654	0.472	2.402	3.346	0.970
5/8	S-1210L	1.181	1.654	0.472	2.402	3.346	1.020
11/16	S-12011L	1.211	1.654	0.472	2.402	3.346	1.040
3/4	S-1212L	1.260	1.654	0.472	2.402	3.346	1.050
13/16	S-1213L	1.417	1.654	0.512	2.402	3.346	1.190
7/8	S-1214L	1.535	1.654	0.512	2.402	3.346	1.290
15/16	S-1215L	1.535	1.654	0.591	2.402	3.346	1.310
1	S-1216L	1.614	1.654	0.591	2.598	3.543	1.360
1.1/16	S-1217L	1.693	1.693	0.630	2.598	3.543	1.480
1.1/8	S-1218L	1.850	1.732	0.709	2.598	3.543	1.690
1.3/16	S-1219L	1.880	1.732	0.709	2.598	3.543	1.710
1.1/4	S-1220L	1.929	1.732	0.709	2.598	3.543	1.760
1.5/16	S-1221L	2.047	1.732	0.787	2.598	3.543	1.910
1.3/8	S-1222L	2.126	2.126	0.787	2.598	3.543	2.280
1.7/16	S-1223L	2.156	2.126	0.787	2.598	3.543	2.300
1.1/2	S-1224L	2.244	2.126	0.906	2.598	3.543	2.470
1.9/16	S-1225L	2.402	2.126	0.906	2.598	3.543	2.700
1.5/8	S-1226L	2.441	2.126	0.984	2.598	3.543	2.730
1.11/16	S-1227L	2.480	2.126	0.984	2.598	3.543	2.760
1.3/4	S-1228L	2.638	2.126	0.984	2.992	3.937	3.440
1.13/16	S-1229L	2.456	2.126	1.102	2.992	3.937	3.410
1.7/8	S-1230L	2.456	2.126	1.102	2.992	3.937	3.410
2	S-1232L	2.731	2.441	1.181	2.992	3.937	4.180

IMPACT SOCKETS 3/4"

www.powermasteramerica.com

3/4"

# IMPACT SOCKETS

## METRIC BIHEXAGON

A/F mm	MODEL NO.	D1 mm	D2 mm	T mm	C mm	OAL mm	Wt. Kg.
17	12M17DH	32.0	44.0	12.0	20.0	45.0	0.370
19	12M19DH	33.0	44.0	12.0	20.0	45.0	0.370
21	12M21DH	36.0	44.0	13.0	23.0	48.0	0.380
22	12M22DH	37.0	44.0	13.0	23.0	48.0	0.380
23	12M23DH	41.0	44.0	13.0	23.0	48.0	0.390
24	12M24DH	41.0	44.0	16.0	23.0	48.0	0.400
26	12M26DH	41.0	44.0	16.0	23.0	48.0	0.400
27	12M27DH	43.0	44.0	16.0	23.0	48.0	0.400
28	12M28DH	45.0	44.0	18.0	23.0	48.0	0.410
30	12M30DH	47.0	44.0	18.0	27.0	52.0	0.425
32	12M32DH	50.0	44.0	19.0	27.0	52.0	0.460
33	12M33DH	50.0	44.0	19.0	30.0	55.0	0.480
34	12M34DH	52.0	44.0	20.0	30.0	55.0	0.500
36	12M36DH	54.0	44.0	20.0	31.0	56.0	0.575
38	12M38DH	57.0	44.0	20.0	34.0	59.0	0.600
41	12M41DH	61.0	44.0	22.0	34.0	59.0	0.625
42	12M42DH	64.0	44.0	22.0	34.0	59.0	0.625
43	12M43DH	64.0	44.0	22.0	39.0	64.0	0.625
46	12M46DH	67.0	54.0	23.0	39.0	64.0	0.825
50	12M50DH	73.0	54.0	25.0	42.0	67.0	1.300
55	12M55DH	78.0	54.0	28.0	46.0	71.0	1.850
60	12M60DH	84.0	54.0	30.0	50.0	75.0	2.050

## FRACTIONAL BIHEXAGON

A/F inch	MODEL NO.	D1 inch	D2 inch	T inch	C inch	OAL inch	Wt. lbs.
9/16	1209DH	1.023	1.732	0.472	0.771	1.771	0.700
5/8	1210DH	1.181	1.732	0.472	0.771	1.771	0.815
11/16	1211DH	1.259	1.732	0.472	0.771	1.771	0.815
3/4	1212DH	1.299	1.732	0.472	0.771	1.771	0.815
13/16	1213DH	1.417	1.732	0.511	0.889	1.889	0.835
7/8	1214DH	1.456	1.732	0.511	0.889	1.889	0.835
15/16	1215DH	1.614	1.732	0.629	0.889	1.889	0.880
1	1216DH	1.614	1.732	0.629	0.889	1.889	0.880
1.1/16	1217DH	1.629	1.732	0.629	0.889	1.889	0.880
1.1/8	1218DH	1.771	1.732	0.708	0.889	1.889	0.900
1.3/16	1219DH	1.850	1.732	0.708	1.047	2.047	0.935
1.1/4	1220DH	1.968	1.732	0.748	1.047	2.047	1.055
1.5/16	1221DH	2.047	1.732	0.748	1.165	2.165	1.100
1.3/8	1222DH	2.125	1.732	0.787	1.165	2.165	1.265
1.7/16	1223DH	2.125	1.732	0.787	1.204	2.204	1.265
1.1/2	1224DH	2.244	1.732	0.787	1.322	2.322	1.320
1.9/16	1225DH	2.401	1.732	0.787	1.322	2.322	1.375
1.5/8	1226DH	2.401	1.732	0.866	1.322	2.322	1.375
1.11/16	1227DH	2.519	1.732	0.866	1.519	2.519	1.375
1.3/4	1228DH	2.519	1.732	0.866	1.519	2.519	1.540
1.13/16	1229DH	2.637	1.732	0.905	1.519	2.519	1.815
1.7/8	1230DH	2.755	2.125	0.905	1.519	2.519	1.815
2	1232DH	2.874	2.125	0.984	1.637	2.637	3.080

## METRIC BISQUARE

A/F mm	MODEL NO.	D1 mm	D2 mm	T mm	C mm	OAL mm	Wt. Kg.
32	12M32DS	62.0	44.0	19.0	27.0	52.0	0.510
33	12M33DS	65.0	44.0	19.0	27.0	52.0	0.540
34	12M34DS	65.0	44.0	20.0	30.0	55.0	0.550
36	12M36DS	68.0	44.0	20.0	30.0	55.0	0.610
38	12M38DS	70.0	54.0	20.0	30.0	55.0	0.700
39	12M39DS	73.0	54.0	20.0	30.0	55.0	0.725
40	12M40DS	73.0	54.0	20.0	30.0	55.0	0.725
41	12M41DS	75.0	54.0	22.0	33.0	58.0	0.750
42	12M42DS	78.0	54.0	22.0	33.0	58.0	0.750
43	12M43DS	78.0	54.0	22.0	33.0	58.0	0.750
46	12M46DS	83.0	54.0	23.0	35.0	60.0	0.940

## FRACTIONAL BISQUARE

A/F inch	MODEL NO.	D1 inch	D2 inch	T inch	C inch	OAL inch	Wt. lbs.
1.1/4	1220DS	2.440	1.732	0.748	1.047	2.047	1.120
1.5/16	1221DS	2.559	1.732	0.748	1.047	2.047	1.210
1.3/8	1222DS	2.677	1.732	0.787	1.165	2.165	1.340
1.7/16	1223DS	2.755	2.125	0.787	1.165	2.165	1.495
1.1/2	1224DS	2.755	2.125	0.787	1.165	2.165	1.540
1.9/16	1225DS	2.874	2.125	0.787	1.166	2.165	1.595
1.5/8	1226DS	2.952	2.125	0.787	1.283	2.283	1.650
1.11/16	1227DS	3.070	2.125	0.866	1.283	2.283	1.650
1.3/4	1228DS	3.149	2.125	0.866	1.283	2.283	1.760
1.13/16	1229DS	3.267	2.125	0.905	1.362	2.362	2.070
1.7/8	1230DS	3.346	2.125	0.905	1.362	2.362	2.110

## METRIC DEEP BISQUARE

A/F mm	MODEL NO.	D1 mm	D2 mm	T mm	C mm	OAL mm	Wt. Kg.
32	12M32LDS	62.0	44.0	19.0	65.0	90.0	0.910
33	12M33LDS	65.0	44.0	19.0	65.0	90.0	0.940
34	12M34LDS	65.0	44.0	20.0	65.0	90.0	0.950
36	12M36LDS	68.0	44.0	20.0	65.0	90.0	1.010
38	12M38LDS	70.0	54.0	20.0	65.0	90.0	1.100
39	12M39LDS	73.0	54.0	20.0	65.0	90.0	1.125
40	12M40LDS	73.0	54.0	20.0	65.0	90.0	1.125
41	12M41LDS	75.0	54.0	22.0	65.0	90.0	1.150
42	12M42LDS	78.0	54.0	22.0	70.0	95.0	1.150
43	12M43LDS	78.0	54.0	22.0	70.0	95.0	1.150
46	12M46LDS	83.0	54.0	23.0	75.0	100.0	1.340

## FRACTIONAL DEEP BISQUARE

A/F inch	MODEL NO.	D1 inch	D2 inch	T inch	C inch	OAL inch	Wt. lbs.
1.1/4	1220LDS	2.440	1.732	0.748	2.543	3.543	2.000
1.5/16	1221LDS	2.559	1.732	0.748	2.543	3.543	2.090
1.3/8	1222LDS	2.677	1.732	0.787	2.543	3.543	2.220
1.7/16	1223LDS	2.755	2.125	0.787	2.543	3.543	2.375
1.1/2	1224LDS	2.755	2.125	0.787	2.543	3.543	2.420
1.9/16	1225LDS	2.874	2.125	0.787	2.543	3.543	2.475
1.5/8	1226LDS	2.952	2.125	0.787	2.543	3.543	2.530
1.11/16	1227LDS	3.070	2.125	0.866	2.740	3.740	2.530
1.3/4	1228LDS	3.149	2.125	0.866	2.740	3.740	2.685
1.13/16	1229LDS	3.267	2.125	0.905	2.937	3.937	2.950
1.7/8	1230LDS	3.346	2.125	0.905	2.937	3.937	3.050

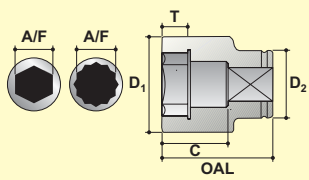

**A/F** Nominal size across flats  
**D1** Max. outside dia. socket end  
**D2** Max. outside dia. sq. drive end  
**OAL** Nominal overall length  
**T** Min. depth of socket form  
**C** Bolt clearance depth

## IMPACT SOCKETS THINWALL

3/4"



### METRIC HEXAGON

A/F mm	MODEL NO.	D1 mm	D2 mm	T mm	C mm	OAL mm	Wt. Kg.
17	S-12M17T	27.9	42.0	12.0	21.0	45.0	0.292
19	S-12M19T	30.4	42.0	12.0	21.0	45.0	0.296
21	S-12M21T	32.9	42.0	13.0	24.0	48.0	0.312
22	S-12M22T	34.3	42.0	13.0	24.0	48.0	0.317
23	S-12M23T	35.3	42.0	13.0	24.0	48.0	0.318
24	S-12M24T	36.8	42.0	15.0	24.0	48.0	0.322
26	S-12M26T	38.5	42.0	15.0	24.0	48.0	0.320
27	S-12M27T	40.5	42.0	16.0	24.0	48.0	0.329
28	S-12M28T	42.0	42.0	16.0	24.0	48.0	0.334
30	S-12M30T	44.4	44.0	18.0	27.0	51.0	0.391
32	S-12M32T	46.8	44.0	18.0	27.0	51.0	0.410
33	S-12M33T	48.0	44.0	18.0	27.0	51.0	0.416
34	S-12M34T	49.3	44.0	20.0	30.0	54.0	0.449
36	S-12M36T	51.9	44.0	20.0	30.0	54.0	0.477
38	S-12M38T	54.4	54.0	23.0	35.0	59.0	0.684
41	S-12M41T	58.4	54.0	23.0	35.0	59.0	0.736
42	S-12M42T	59.4	54.0	25.0	35.0	59.0	0.737
43	S-12M43T	60.4	54.0	25.0	38.0	62.0	0.778
46	S-12M46T	64.0	54.0	25.0	38.0	62.0	0.833

### FRACTIONAL HEXAGON

A/F inch	MODEL NO.	D1 inch	D2 inch	T inch	C inch	OAL inch	Wt. lbs.
11/16	S-1211T	1.078	1.654	0.472	0.827	1.772	0.640
3/4	S-1212T	1.197	1.654	0.472	0.827	1.772	0.650
13/16	S-1213T	1.295	1.654	0.512	0.945	1.890	0.690
7/8	S-1214T	1.390	1.654	0.512	0.945	1.890	0.700
15/16	S-1215T	1.449	1.654	0.591	0.945	1.890	0.710
1	S-1216T	1.516	1.654	0.591	0.945	1.890	0.710
1.1/16	S-1217T	1.594	1.654	0.630	0.945	1.890	0.720
1.1/8	S-1218T	1.748	1.732	0.709	1.063	2.008	0.860
1.3/16	S-1219T	1.778	1.732	0.709	1.063	2.008	0.880
1.1/4	S-1220T	1.843	1.732	0.709	1.063	2.008	0.900
1.5/16	S-1221T	1.941	1.732	0.787	1.181	2.126	0.990
1.3/8	S-1222T	2.043	1.732	0.787	1.181	2.126	1.050
1.7/16	S-1223T	2.073	1.732	0.787	1.181	2.126	1.080
1.1/2	S-1224T	2.142	2.126	0.906	1.378	2.323	1.500
1.9/16	S-1225T	2.299	2.126	0.906	1.378	2.323	1.620
1.5/8	S-1226T	2.378	2.126	0.984	1.496	2.441	1.710
1.11/16	S-1227T	2.378	2.126	0.984	1.496	2.441	1.710
1.3/4	S-1228T	2.500	2.126	0.984	1.496	2.441	1.810
1.13/16	S-1229T	2.530	2.126	0.984	1.496	2.441	1.840

### METRIC DEEP HEXAGON

A/F mm	MODEL NO.	D1 mm	D2 mm	T mm	C mm	OAL mm	Wt. Kg.
17	S-12M17LT	27.9	42.0	12.0	61.0	85.0	0.421
19	S-12M19LT	30.4	42.0	12.0	61.0	85.0	0.445
21	S-12M21LT	32.9	42.0	13.0	61.0	85.0	0.470
22	S-12M22LT	34.3	42.0	13.0	61.0	85.0	0.486
23	S-12M23LT	35.3	42.0	13.0	61.0	85.0	0.494
24	S-12M24LT	36.8	42.0	15.0	61.0	85.0	0.512
26	S-12M26LT	38.5	42.0	15.0	66.0	90.0	0.545
27	S-12M27LT	40.5	42.0	16.0	66.0	90.0	0.643
28	S-12M28LT	42.0	42.0	16.0	66.0	90.0	0.621
30	S-12M30LT	44.4	44.0	18.0	66.0	90.0	0.682
32	S-12M32LT	46.8	44.0	18.0	66.0	90.0	0.726
33	S-12M33LT	48.0	44.0	18.0	66.0	90.0	0.744
34	S-12M34LT	49.3	44.0	20.0	66.0	90.0	0.767
36	S-12M36LT	51.9	44.0	20.0	66.0	90.0	0.822
38	S-12M38LT	54.4	54.0	23.0	66.0	90.0	1.020
41	S-12M41LT	58.4	54.0	23.0	66.0	90.0	1.103
42	S-12M42LT	59.4	54.0	25.0	66.0	90.0	1.092
43	S-12M43LT	60.4	54.0	25.0	66.0	90.0	1.095
46	S-12M46LT	64.0	54.0	25.0	66.0	90.0	1.169

### FRACTIONAL DEEP HEXAGON

A/F inch	MODEL NO.	D1 inch	D2 inch	T inch	C inch	OAL inch	Wt. lbs.
11/16	S-1211LT	1.128	1.654	0.472	2.402	3.346	0.950
3/4	S-1212LT	1.197	1.654	0.472	2.402	3.346	0.980
13/16	S-1213LT	1.295	1.654	0.512	2.402	3.346	1.030
7/8	S-1214LT	1.390	1.654	0.512	2.402	3.346	1.090
15/16	S-1215LT	1.449	1.654	0.591	2.402	3.346	1.130
1	S-1216LT	1.516	1.654	0.591	2.598	3.543	1.200
1.1/16	S-1217LT	1.594	1.654	0.630	2.598	3.543	1.410
1.1/8	S-1218LT	1.748	1.732	0.709	2.598	3.543	1.500
1.3/16	S-1219LT	1.778	1.732	0.709	2.598	3.543	1.530
1.1/4	S-1220LT	1.843	1.732	0.709	2.598	3.543	1.600
1.5/16	S-1221LT	1.941	1.732	0.787	2.598	3.543	1.690
1.3/8	S-1222LT	2.043	1.732	0.787	2.598	3.543	1.810
1.7/16	S-1223LT	2.073	1.732	0.787	2.598	3.543	1.830
1.1/2	S-1224LT	2.142	2.126	0.906	2.598	3.543	2.240
1.9/16	S-1225LT	2.299	2.126	0.906	2.598	3.543	2.430
1.5/8	S-1226LT	2.378	2.126	0.984	2.598	3.543	2.410
1.11/16	S-1227LT	2.378	2.126	0.984	2.598	3.543	2.410
1.3/4	S-1228LT	2.520	2.126	0.984	2.598	3.543	2.570
1.13/16	S-1229LT	2.550	2.126	0.984	2.598	3.543	2.600

IMPACT SOCKETS 3/4"

www.powermasteramerica.com

3/4"

IMPACT ACCESSORIES



METRIC HEX DRIVER SOCKETS

HEX A/F mm	MODEL NO.	BIT LENGTH	OAL mm	Wt Kg.
8	12M08H	12.0	62.0	0.240
10	12M10H	18.0	65.0	0.250
12	12M12H	25.0	75.0	0.300
14	12M14H	25.0	75.0	0.300
17	12M17H	35.0	88.0	0.450
19	12M19H	35.0	88.0	0.450
22	12M22H	40.0	93.0	0.500
24	12M24H	45.0	93.0	0.550
27	12M27H	45.0	100.0	0.700

FRACTIONAL HEX DRIVE SOCKETS

HEX A/F inch	MODEL NO.	BIT LENGTH	OAL inch	Wt lbs.
3/8	1206H	0.708	2.559	0.550
7/16	1207H	0.708	2.559	0.550
1/2	1208H	0.984	2.952	0.660
9/16	1209H	0.984	2.952	0.660
5/8	1210H	1.377	3.464	0.715
3/4	1212H	1.377	3.464	0.990
13/16	1213H	1.574	3.661	1.100
7/8	1214H	1.574	3.661	1.210
1	1216H	1.771	3.937	1.210

REGULAR EXTENSIONS

OAL mm (inch)	MODEL NO.	SHANK DIA mm (inch)	HEAD DIA mm (inch)	Wt Kg. (lbs.)
75 (3")	E1203	25.0 (0.984)	44.0 (1.732)	0.60 (1.32)
125 (5")	E1205			0.80 (1.76)
175 (7")	E1207			1.00 (2.20)
250 (10")	E1210	25.0 (0.984)	44.0 (1.732)	1.20 (2.64)
330 (13")	E1213			1.50 (3.30)



SQUARE ADAPTORS

SIZE	MODEL NO.	HEAD DIA mm (inch)	OAL mm (inch)	Wt Kg. (lbs.)
3/4" F X 1/2" M	A1208	44.0 (1.732)	56.0 (2.204)	0.33 (0.72)
3/4" F X 1" M	A1216		65.0 (2.559)	0.45 (0.99)



UNIVERSAL JOINT

SQUARE DRIVE	MODEL NO.	DIA mm (inch)	OAL mm (inch)	Wt Kg. (lbs.)
3/4"	U1212	44.0 (1.732)	94.0 (3.700)	0.60 (1.32)



DOUBLE MALE EXTENSIONS

OAL mm (inch)	MODEL NO.	SHANK DIA mm (inch)	HEAD DIA mm (inch)	Wt Kg. (lbs.)
75 (3")	S1203	25.0 (0.984)	19.0 (0.750)	0.40 (0.88)
125 (5")	S1205			0.55 (1.21)
175 (7")	S1207			0.75 (1.65)
250 (10")	S1210	25.0 (0.984)	19.0 (0.750)	0.95 (2.09)
330 (13")	S1213			1.05 (2.31)
410 (16")	S1216			1.60 (3.50)



DOUBLE FEMALE ADAPTORS

SIZE	MODEL NO.	HEAD DIA mm (inch)	OAL mm (inch)	Wt Kg. (lbs.)
3/4" F X 1/2" F	AN1208	44.0 (1.732)	55.0 (2.165)	0.45 (0.99)
3/4" F X 1" F	AN1212		63.0 (2.480)	0.57 (1.25)



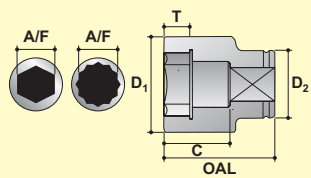

**A/F** Nominal size across flats  
**D1** Max. outside dia. socket end  
**D2** Max. outside dia. sq. drive end  
**OAL** Nominal overall length  
**T** Min. depth of socket form  
**C** Bolt clearance depth

# IMPACT SOCKETS



## METRIC HEXAGON



## FRACTIONAL HEXAGON



A/F mm	MODEL NO.	D1 mm	D2 mm	T mm	C mm	OAL mm	Wt. Kg.
19	S-16M19	36.0	51.0	14.0	25.0	55.0	0.51
20	S-16M20	36.0	51.0	14.0	25.0	55.0	0.50
21	S-16M21	38.0	51.0	14.0	25.0	55.0	0.52
22	S-16M22	40.0	51.0	14.0	25.0	55.0	0.53
23	S-16M23	40.0	51.0	14.0	25.0	55.0	0.52
24	S-16M24	42.0	51.0	16.0	27.0	57.0	0.55
25	S-16M25	43.0	51.0	16.0	27.0	57.0	0.55
26	S-16M26	45.0	51.0	16.0	27.0	57.0	0.56
27	S-16M27	46.0	51.0	16.0	27.0	57.0	0.57
28	S-16M28	47.0	51.0	16.0	27.0	57.0	0.57
29	S-16M29	48.0	51.0	18.0	29.0	59.0	0.59
30	S-16M30	49.0	54.0	18.0	29.0	59.0	0.66
31	S-16M31	50.0	54.0	18.0	29.0	59.0	0.66
32	S-16M32	52.0	54.0	18.0	29.0	59.0	0.68
33	S-16M33	54.0	54.0	18.0	29.0	59.0	0.69
34	S-16M34	54.0	54.0	20.0	31.0	61.0	0.70
35	S-16M35	54.0	54.0	20.0	31.0	61.0	0.69
36	S-16M36	57.0	54.0	20.0	31.0	61.0	0.78
37	S-16M37	57.0	54.0	20.0	31.0	61.0	0.76
38	S-16M38	59.0	54.0	22.0	34.0	64.0	0.84
39	S-16M39	60.0	54.0	22.0	34.0	64.0	0.88
40	S-16M40	60.0	54.0	22.0	34.0	64.0	0.85
41	S-16M41	62.0	54.0	22.0	34.0	64.0	0.90
42	S-16M42	64.0	54.0	24.0	36.0	66.0	0.97
43	S-16M43	65.0	54.0	24.0	36.0	66.0	0.98
44	S-16M44	66.0	54.0	24.0	36.0	66.0	0.98
45	S-16M45	68.0	54.0	24.0	36.0	66.0	1.03
46	S-16M46	68.0	54.0	26.0	38.0	68.0	1.02
47	S-16M47	71.0	54.0	26.0	38.0	68.0	1.12
48	S-16M48	71.0	54.0	26.0	38.0	68.0	1.08
49	S-16M49	74.0	54.0	28.0	40.0	70.0	1.17
50	S-16M50	74.0	54.0	28.0	40.0	70.0	1.17
51	S-16M51	77.0	62.0	28.0	40.0	70.0	1.40
52	S-16M52	77.0	62.0	28.0	40.0	70.0	1.40
54	S-16M54	79.0	62.0	28.0	40.0	70.0	1.42
55	S-16M55	79.0	62.0	30.0	44.0	74.0	1.45
56	S-16M56	80.0	62.0	30.0	44.0	74.0	1.46
57	S-16M57	84.0	62.0	30.0	44.0	74.0	1.59
58	S-16M58	84.0	62.0	30.0	44.0	74.0	1.59
59	S-16M59	87.0	62.0	32.0	47.0	77.0	1.75
60	S-16M60	87.0	62.0	32.0	47.0	77.0	1.75
62	S-16M62	90.0	62.0	34.0	49.0	79.0	1.89
65	S-16M65	93.0	62.0	36.0	51.0	81.0	1.99
70	S-16M70	99.0	86.0	38.0	54.0	84.0	2.81
75	S-16M75	104.0	86.0	40.0	56.0	89.0	3.08
80	S-16M80	112.0	86.0	42.0	58.0	91.0	3.54
85	S-16M85	119.0	86.0	44.0	60.0	93.0	3.85
90	S-16M90	122.0	86.0	46.0	62.0	95.0	3.84
95	S-16M95	130.0	106.0	48.0	64.0	97.0	5.13
100	S-16M100	134.0	106.0	50.0	66.0	99.0	5.20
105	S-16M105	142.0	106.0	52.0	68.0	101.0	5.83
110	S-16M110	147.0	106.0	54.0	72.0	105.0	6.00
115	S-16M115	153.0	127.0	56.0	72.0	105.0	7.36

A/F inch	MODEL NO.	D1 inch	D2 inch	T inch	C inch	OAL inch	Wt. lbs.
3/4	S-1612	1.417	2.008	0.551	0.984	2.165	1.13
13/16	S-1613	1.496	2.008	0.551	0.984	2.165	1.13
7/8	S-1614	1.575	2.008	0.551	0.984	2.165	1.14
15/16	S-1615	1.654	2.008	0.630	1.063	2.244	1.20
1	S-1616	1.772	2.008	0.630	1.063	2.244	1.24
1.1/16	S-1617	1.811	2.008	0.630	1.063	2.244	1.25
1.1/8	S-1618	1.890	2.008	0.709	1.142	2.323	1.29
1.3/16	S-1619	1.969	2.126	0.709	1.142	2.323	1.45
1.1/4	S-1620	2.047	2.126	0.709	1.142	2.323	1.49
1.5/16	S-1621	2.126	2.126	0.787	1.220	2.402	1.54
1.3/8	S-1622	2.126	2.126	0.787	1.220	2.402	1.51
1.7/16	S-1623	2.244	2.126	0.787	1.220	2.402	1.68
1.1/2	S-1624	2.323	2.126	0.866	1.339	2.520	1.86
1.9/16	S-1625	2.362	2.126	0.866	1.339	2.520	1.88
1.5/8	S-1626	2.520	2.126	0.945	1.417	2.598	2.13
1.11/16	S-1627	2.559	2.126	0.945	1.417	2.598	2.15
1.3/4	S-1628	2.677	2.126	0.945	1.417	2.598	2.27
1.13/16	S-1629	2.677	2.126	1.024	1.496	2.677	2.25
1.7/8	S-1630	2.795	2.126	1.024	1.496	2.677	2.37
1.15/16	S-1631	2.795	2.126	1.024	1.496	2.677	2.37
2	S-1632	2.963	2.126	1.102	1.575	2.756	2.67
2.1/16	S-1633	2.963	2.126	1.102	1.575	2.756	2.67
2.1/8	S-1634	3.110	2.441	1.102	1.575	2.756	3.13
2.3/16	S-1635	3.150	2.441	1.181	1.732	2.913	3.21
2.1/4	S-1636	3.307	2.441	1.181	1.732	2.913	3.50
2.5/16	S-1637	3.307	2.441	1.181	1.732	2.913	3.50
2.3/8	S-1638	3.405	2.441	1.260	1.850	3.031	3.77
2.7/16	S-1639	3.543	2.441	1.339	1.929	3.110	4.17
2.1/2	S-1640	3.543	2.441	1.339	1.929	3.110	4.17
2.9/16	S-1641	3.711	2.441	1.417	2.008	3.189	4.38
2.5/8	S-1642	3.711	2.441	1.417	2.008	3.189	4.38
2.11/16	S-1643	3.898	3.386	1.496	2.126	3.307	6.19
2.3/4	S-1644	3.898	3.386	1.496	2.126	3.307	6.19
2.13/16	S-1645	3.898	3.386	1.496	2.126	3.307	6.19
2.7/8	S-1646	4.094	3.386	1.575	2.205	3.504	6.77
2.15/16	S-1647	4.094	3.386	1.575	2.205	3.504	6.77
3	S-1648	4.094	3.386	1.575	2.205	3.504	6.77
3.1/16	S-1649	4.425	3.386	1.654	2.283	3.583	7.80
3.1/8	S-1650	4.425	3.386	1.654	2.283	3.583	7.80
3.3/16	S-1651	4.425	3.386	1.654	2.283	3.583	7.80
3.1/4	S-1652	4.651	3.386	1.732	2.362	3.661	8.13
3.5/16	S-1653	4.742	3.386	1.732	2.362	3.661	8.48
3.3/8	S-1654	4.742	3.386	1.732	2.362	3.661	8.48
3.7/16	S-1655	4.803	3.386	1.811	2.441	3.740	8.44
3.1/2	S-1656	4.803	3.386	1.811	2.441	3.740	8.44
3.5/8	S-1658	5.118	4.173	1.890	2.520	3.819	11.29
3.3/4	S-1660	5.118	4.173	1.890	2.520	3.819	11.29
3.7/8	S-1662	5.276	4.173	1.969	2.598	3.898	11.44
4	S-1664	5.591	4.173	2.047	2.677	3.976	12.82
4.1/8	S-1666	5.591	4.173	2.047	2.677	3.976	12.82
4.1/4	S-1668	5.727	4.173	2.126	2.835	4.134	13.05
4.3/8	S-1670	6.024	5.000	2.205	2.835	4.134	16.20
4.1/2	S-1672	6.024	5.000	2.205	2.835	4.134	16.20





# IMPACT SOCKETS

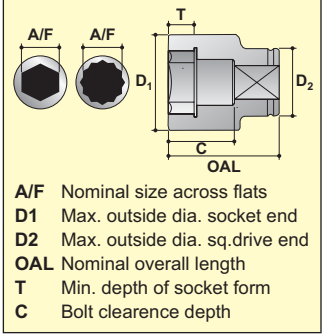

## METRIC DEEP HEXAGON

## FRACTIONAL DEEP HEXAGON

A/F mm	MODEL NO.	D1 mm	D2 mm	T mm	C mm	OAL mm	Wt. Kg.
19	S-16M19L	36.0	51.0	14.0	72.0	102.0	0.79
20	S-16M20L	36.0	51.0	14.0	72.0	102.0	0.76
21	S-16M21L	38.0	51.0	14.0	72.0	102.0	0.81
22	S-16M22L	40.0	51.0	14.0	72.0	102.0	0.86
23	S-16M23L	40.0	51.0	14.0	72.0	102.0	0.84
24	S-16M24L	42.0	51.0	16.0	72.0	102.0	0.89
25	S-16M25L	43.0	51.0	16.0	72.0	102.0	0.90
26	S-16M26L	45.0	51.0	16.0	72.0	102.0	0.95
27	S-16M27L	46.0	51.0	16.0	72.0	102.0	0.97
28	S-16M28L	47.0	51.0	16.0	72.0	102.0	0.98
29	S-16M29L	48.0	51.0	18.0	72.0	102.0	0.99
30	S-16M30L	49.0	54.0	18.0	72.0	102.0	1.07
31	S-16M31L	50.0	54.0	18.0	72.0	102.0	1.09
32	S-16M32L	52.0	54.0	18.0	72.0	102.0	1.14
33	S-16M33L	54.0	54.0	18.0	72.0	102.0	1.19
34	S-16M34L	54.0	54.0	20.0	72.0	102.0	1.16
35	S-16M35L	54.0	54.0	20.0	72.0	102.0	1.13
36	S-16M36L	57.0	54.0	20.0	69.0	102.0	1.31
37	S-16M37L	57.0	54.0	20.0	69.0	102.0	1.28
38	S-16M38L	59.0	54.0	22.0	69.0	102.0	1.38
39	S-16M39L	60.0	54.0	22.0	69.0	102.0	1.41
40	S-16M40L	60.0	54.0	22.0	69.0	102.0	1.37
41	S-16M41L	62.0	54.0	22.0	69.0	102.0	1.45
42	S-16M42L	64.0	54.0	24.0	69.0	102.0	1.53
43	S-16M43L	66.0	54.0	24.0	69.0	102.0	1.61
44	S-16M44L	66.0	54.0	24.0	69.0	102.0	1.56
45	S-16M45L	68.0	54.0	24.0	69.0	102.0	1.65
46	S-16M46L	68.0	54.0	26.0	69.0	102.0	1.59
47	S-16M47L	71.0	54.0	26.0	67.0	102.0	1.73
48	S-16M48L	71.0	54.0	26.0	67.0	102.0	1.68
49	S-16M49L	74.0	54.0	28.0	80.0	110.0	1.96
50	S-16M50L	74.0	54.0	28.0	80.0	110.0	1.96
51	S-16M51L	77.0	62.0	28.0	75.0	110.0	2.23
52	S-16M52L	77.0	62.0	28.0	75.0	110.0	2.23
54	S-16M54L	79.0	62.0	28.0	75.0	110.0	2.26
55	S-16M55L	79.0	62.0	30.0	75.0	110.0	2.19
56	S-16M56L	80.0	62.0	30.0	75.0	110.0	2.21
57	S-16M57L	84.0	62.0	30.0	75.0	110.0	2.42
58	S-16M58L	84.0	62.0	30.0	75.0	110.0	2.42
59	S-16M59L	87.0	62.0	32.0	80.0	115.0	2.71
60	S-16M60L	87.0	62.0	32.0	80.0	115.0	2.71
62	S-16M62L	90.0	62.0	32.0	80.0	115.0	2.86
65	S-16M65L	93.0	62.0	34.0	80.0	115.0	2.90
70	S-16M70L	99.0	62.0	36.0	85.0	120.0	3.28
75	S-16M75L	104.0	86.0	38.0	85.0	120.0	4.17
80	S-16M80L	112.0	86.0	40.0	85.0	120.0	4.73
85	S-16M85L	119.0	86.0	42.0	90.0	125.0	5.27
90	S-16M90L	122.0	86.0	44.0	90.0	125.0	5.15
95	S-16M95L	130.0	106.0	46.0	95.0	130.0	6.91
100	S-16M100L	134.0	106.0	48.0	95.0	130.0	6.88
105	S-16M105L	142.0	106.0	50.0	95.0	130.0	7.58
110	S-16M110L	147.0	106.0	52.0	105.0	140.0	8.38
115	S-16M115L	153.0	127.0	54.0	105.0	140.0	9.81

A/F inch	MODEL NO.	D1 inch	D2 inch	T inch	C inch	OAL inch	Wt. lbs.
3/4	S-1612L	1.417	2.008	0.551	2.835	4.016	1.73
13/16	S-1613L	1.496	2.008	0.551	2.835	4.016	1.78
7/8	S-1614L	1.575	2.008	0.551	2.835	4.016	1.85
15/16	S-1615L	1.654	2.008	0.630	2.835	4.016	1.95
1	S-1616L	1.772	2.008	0.630	2.835	4.016	2.10
1.1/16	S-1617L	1.811	2.008	0.630	2.835	4.016	2.13
1.1/8	S-1618L	1.890	2.008	0.709	2.835	4.016	2.18
1.3/16	S-1619L	1.969	2.126	0.709	2.835	4.016	2.39
1.1/4	S-1620L	2.047	2.126	0.709	2.835	4.016	2.51
1.5/16	S-1621L	2.126	2.126	0.787	2.835	4.016	2.56
1.3/8	S-1622L	2.126	2.126	0.787	2.835	4.016	2.49
1.7/16	S-1623L	2.244	2.126	0.787	2.717	4.016	2.82
1.1/2	S-1624L	2.323	2.126	0.866	2.717	4.016	3.03
1.9/16	S-1625L	2.362	2.126	0.866	2.717	4.016	3.02
1.5/8	S-1626L	2.520	2.126	0.945	2.717	4.016	3.36
1.11/16	S-1627L	2.596	2.126	0.945	2.717	4.016	3.53
1.3/4	S-1628L	2.677	2.126	0.945	2.717	4.016	3.62
1.13/16	S-1629L	2.677	2.126	1.024	2.717	4.016	3.49
1.7/8	S-1630L	2.795	2.126	1.024	2.638	4.016	3.69
1.15/16	S-1631L	2.795	2.126	1.024	2.638	4.016	3.69
2	S-1632L	2.963	2.126	1.102	3.150	4.331	4.41
2.1/16	S-1633L	2.923	2.126	1.102	3.150	4.331	4.41
2.1/8	S-1634L	3.110	2.441	1.181	2.953	4.331	4.81
2.3/16	S-1635L	3.150	2.441	1.181	2.953	4.331	4.85
2.1/4	S-1636L	3.307	2.441	1.181	2.953	4.331	5.32
2.5/16	S-1637L	2.598	2.126	0.945	2.717	4.016	3.44
2.3/8	S-1638L	3.405	2.441	1.260	3.150	4.528	6.04
2.7/16	S-1639L	3.543	2.441	1.260	3.150	4.528	6.30
2.1/2	S-1640L	2.796	2.126	1.024	2.638	4.016	3.81
2.9/16	S-1641L	3.741	2.441	1.339	3.150	4.528	6.38
2.5/8	S-1642L	3.741	2.441	1.339	3.150	4.528	6.38
2.11/16	S-1643L	3.031	2.441	1.102	2.953	4.331	4.90
2.3/4	S-1644L	3.898	2.441	1.417	3.346	4.724	7.22
2.13/16	S-1645L	3.898	2.441	1.417	3.346	4.724	7.22
2.7/8	S-1646L	4.094	3.386	1.496	3.346	4.724	9.18
2.15/16	S-1647L	4.094	3.386	1.496	3.346	4.724	9.18
3	S-1648L	4.094	3.386	1.496	3.346	4.724	9.18
3.1/16	S-1649L	4.425	3.386	1.575	3.346	4.724	10.40
3.1/8	S-1650L	4.425	3.386	1.575	3.346	4.724	10.40
3.3/16	S-1651L	4.425	3.386	1.575	3.346	4.724	10.40
3.1/4	S-1652L	4.651	3.386	1.654	3.543	4.921	10.84
3.5/16	S-1653L	4.751	3.386	1.654	3.543	4.921	11.60
3.3/8	S-1654L	4.751	3.386	1.654	3.543	4.921	11.60
3.7/16	S-1655L	4.803	3.386	1.732	3.543	4.921	11.45
3.1/2	S-1656L	4.803	3.386	1.732	3.543	4.921	11.45
3.5/8	S-1658L	5.118	4.173	1.811	3.740	5.118	15.20
3.3/4	S-1660L	5.118	4.173	1.811	3.740	5.118	15.20
3.7/8	S-1662L	5.276	4.173	1.890	3.740	5.118	15.14
4	S-1664L	5.591	4.173	1.969	3.740	5.118	16.68
4.1/8	S-1666L	5.591	4.173	1.969	3.740	5.118	16.68
4.1/4	S-1668L	5.787	4.173	2.047	4.134	5.512	18.58
4.3/8	S-1670L	6.024	5.000	2.126	4.134	5.512	21.59
4.1/2	S-1672L	6.024	5.000	2.126	4.134	5.512	21.59

# IMPACT SOCKETS



## METRIC BIHEXAGON



A/F mm	MODEL NO.	D1 mm	D2 mm	T mm	C mm	OAL mm	Wt. Kg.
19	16M19DH	36.0	51.0	14.0	25.0	55.0	0.51
20	16M20DH	36.0	51.0	14.0	25.0	55.0	0.50
21	16M21DH	38.0	51.0	14.0	25.0	55.0	0.52
22	16M22DH	40.0	51.0	14.0	25.0	55.0	0.53
23	16M23DH	40.0	51.0	14.0	25.0	55.0	0.52
24	16M24DH	42.0	51.0	16.0	27.0	57.0	0.55
25	16M25DH	43.0	51.0	16.0	27.0	57.0	0.55
26	16M26DH	45.0	51.0	16.0	27.0	57.0	0.56
27	16M27DH	46.0	51.0	16.0	27.0	57.0	0.57
28	16M28DH	47.0	51.0	16.0	27.0	57.0	0.57
29	16M29DH	48.0	51.0	18.0	29.0	59.0	0.59
30	16M30DH	49.0	54.0	18.0	29.0	59.0	0.66
31	16M31DH	50.0	54.0	18.0	29.0	59.0	0.66
32	16M32DH	52.0	54.0	18.0	29.0	59.0	0.68
33	16M33DH	54.0	54.0	18.0	29.0	59.0	0.69
34	16M34DH	54.0	54.0	20.0	31.0	61.0	0.70
35	16M35DH	54.0	54.0	20.0	31.0	61.0	0.69
36	16M36DH	57.0	54.0	20.0	31.0	61.0	0.78
37	16M37DH	57.0	54.0	20.0	31.0	61.0	0.76
38	16M38DH	59.0	54.0	22.0	34.0	64.0	0.84
39	16M39DH	60.0	54.0	22.0	34.0	64.0	0.88
40	16M40DH	60.0	54.0	22.0	34.0	64.0	0.85
41	16M41DH	62.0	54.0	22.0	34.0	64.0	0.90
42	16M42DH	64.0	54.0	24.0	36.0	66.0	0.97
43	16M43DH	65.0	54.0	24.0	36.0	66.0	0.98
44	16M44DH	66.0	54.0	24.0	36.0	66.0	0.98
45	16M45DH	68.0	54.0	24.0	36.0	66.0	1.03
46	16M46DH	68.0	54.0	26.0	38.0	68.0	1.02
47	16M47DH	71.0	54.0	26.0	38.0	68.0	1.12
48	16M48DH	71.0	54.0	26.0	38.0	68.0	1.08
49	16M49DH	74.0	54.0	28.0	40.0	70.0	1.17
50	16M50DH	74.0	54.0	28.0	40.0	70.0	1.17
51	16M51DH	77.0	62.0	28.0	40.0	70.0	1.40
52	16M52DH	77.0	62.0	28.0	40.0	70.0	1.40
54	16M54DH	79.0	62.0	28.0	40.0	70.0	1.42
55	16M55DH	79.0	62.0	30.0	44.0	74.0	1.45
56	16M56DH	80.0	62.0	30.0	44.0	74.0	1.46
57	16M57DH	84.0	62.0	30.0	44.0	74.0	1.59
58	16M58DH	84.0	62.0	30.0	44.0	74.0	1.59
59	16M59DH	87.0	62.0	32.0	47.0	77.0	1.75
60	16M60DH	87.0	62.0	32.0	47.0	77.0	1.75
62	16M62DH	90.0	62.0	34.0	49.0	79.0	1.89
65	16M65DH	93.0	62.0	36.0	51.0	81.0	1.99
70	16M70DH	99.0	86.0	38.0	54.0	84.0	2.81
75	16M75DH	104.0	86.0	40.0	56.0	89.0	3.08
80	16M80DH	112.0	86.0	42.0	58.0	91.0	3.54
85	16M85DH	119.0	86.0	44.0	60.0	93.0	3.85
90	16M90DH	122.0	86.0	46.0	62.0	95.0	3.84
95	16M95DH	130.0	106.0	48.0	64.0	97.0	5.13

## FRACTIONAL BIHEXAGON



A/F inch	MODEL NO.	D1 inch	D2 inch	T inch	C inch	OAL inch	Wt. lbs.
3/4	1612DH	1.417	2.008	0.551	0.984	2.165	1.13
13/16	1613DH	1.496	2.008	0.551	0.984	2.165	1.13
7/8	1614DH	1.575	2.008	0.551	0.984	2.165	1.14
15/16	1615DH	1.654	2.008	0.630	1.063	2.244	1.20
1	1616DH	1.772	2.008	0.630	1.063	2.244	1.24
1.1/16	1617DH	1.811	2.008	0.630	1.063	2.244	1.25
1.1/8	1618DH	1.890	2.008	0.709	1.142	2.323	1.29
1.3/16	1619DH	1.969	2.126	0.709	1.142	2.323	1.45
1.1/4	1620DH	2.047	2.126	0.709	1.142	2.323	1.49
1.5/16	1621DH	2.126	2.126	0.787	1.220	2.402	1.54
1.3/8	1622DH	2.126	2.126	0.787	1.220	2.402	1.51
1.7/16	1623DH	2.244	2.126	0.787	1.220	2.402	1.68
1.1/2	1624DH	2.323	2.126	0.866	1.339	2.520	1.86
1.9/16	1625DH	2.362	2.126	0.866	1.339	2.520	1.88
1.5/8	1626DH	2.520	2.126	0.945	1.417	2.598	2.13
1.11/16	1627DH	2.559	2.126	0.945	1.417	2.598	2.15
1.3/4	1628DH	2.677	2.126	0.945	1.417	2.598	2.27
1.13/16	1629DH	2.677	2.126	1.024	1.496	2.677	2.25
1.7/8	1630DH	2.795	2.126	1.024	1.496	2.677	2.37
1.15/16	1631DH	2.795	2.126	1.024	1.496	2.677	2.37
2	1632DH	2.963	2.126	1.102	1.575	2.756	2.67
2.1/16	1633DH	2.963	2.126	1.102	1.575	2.756	2.67
2.1/8	1634DH	3.110	2.441	1.102	1.575	2.756	3.13
2.3/16	1635DH	3.150	2.441	1.181	1.732	2.913	3.21
2.1/4	1636DH	3.307	2.441	1.181	1.732	2.913	3.50
2.5/16	1637DH	3.307	2.441	1.181	1.732	2.913	3.50
2.3/8	1638DH	3.405	2.441	1.260	1.850	3.031	3.77
2.7/16	1639DH	3.543	2.441	1.339	1.929	3.110	4.17
2.1/2	1640DH	3.543	2.441	1.339	1.929	3.110	4.17
2.9/16	1641DH	3.711	2.441	1.417	2.008	3.189	4.38
2.5/8	1642DH	3.711	2.441	1.417	2.008	3.189	4.38
2.11/16	1643DH	3.898	3.386	1.496	2.126	3.307	6.19
2.3/4	1644DH	3.898	3.386	1.496	2.126	3.307	6.19
2.13/16	1645DH	3.898	3.386	1.496	2.126	3.307	6.19
2.7/8	1646DH	4.094	3.386	1.575	2.205	3.504	6.77
2.15/16	1647DH	4.094	3.386	1.575	2.205	3.504	6.77
3	1648DH	4.094	3.386	1.575	2.205	3.504	6.77
3.1/16	1649DH	4.425	3.386	1.654	2.283	3.583	7.80
3.1/8	1650DH	4.425	3.386	1.654	2.283	3.583	7.80
3.3/16	1651DH	4.425	3.386	1.654	2.283	3.583	7.80
3.1/4	1652DH	4.651	3.386	1.732	2.362	3.661	8.13
3.5/16	1653DH	4.742	3.386	1.732	2.362	3.661	8.48
3.3/8	1654DH	4.742	3.386	1.732	2.362	3.661	8.48
3.7/16	1655DH	4.803	3.386	1.811	2.441	3.740	8.44
3.1/2	1656DH	4.803	3.386	1.811	2.441	3.740	8.44
3.5/8	1658DH	5.118	4.173	1.890	2.520	3.819	11.29
3.3/4	1660DH	5.118	4.173	1.890	2.520	3.819	11.29
3.7/8	1662DH	5.276	4.173	1.969	2.598	3.898	11.44



# IMPACT SOCKETS

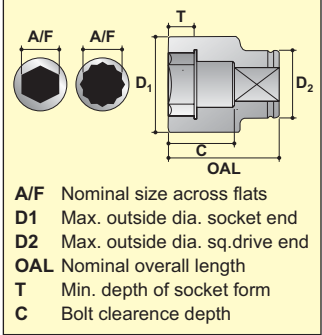

## METRIC BISQUARE

A/F mm	MODEL NO.	D1 mm	D2 mm	T mm	C mm	OAL mm	Wt. Kg.
32	16M32DS	65.0	54.0	21.0	28.0	58.0	0.86
33	16M33DS	65.0	54.0	21.0	28.0	58.0	0.86
34	16M34DS	68.0	54.0	21.0	31.0	61.0	0.90
35	16M35DS	68.0	54.0	21.0	31.0	61.0	0.90
36	16M36DS	71.0	54.0	25.0	31.0	61.0	0.92
38	16M38DS	74.0	54.0	25.0	35.0	65.0	1.15
39	16M39DS	74.0	54.0	25.0	35.0	65.0	1.15
40	16M40DS	77.0	54.0	25.0	35.0	65.0	1.16
41	16M41DS	77.0	54.0	28.0	35.0	65.0	1.16
42	16M42DS	80.0	54.0	28.0	35.0	65.0	1.36
43	16M43DS	80.0	54.0	28.0	40.0	70.0	1.46
46	16M46DS	86.0	54.0	28.0	40.0	70.0	1.50
50	16M50DS	90.0	54.0	28.0	43.0	73.0	1.70
51	16M51DS	93.0	54.0	28.0	43.0	73.0	1.80
54	16M54DS	98.0	54.0	28.0	47.0	77.0	2.25
55	16M55DS	98.0	54.0	30.0	47.0	77.0	2.25
57	16M57DS	103.0	86.0	30.0	47.0	77.0	2.95
60	16M60DS	106.0	86.0	32.0	53.0	83.0	3.20
65	16M65DS	112.0	86.0	38.0	56.0	86.0	3.65

## FRACTIONAL BISQUARE

A/F inch	MODEL NO.	D1 inch	D2 inch	T inch	C inch	OAL inch	Wt. lbs.
1.1/4	1620DS	2.559	2.125	0.826	1.141	2.283	1.89
1.5/16	1621DS	2.559	2.125	0.826	1.141	2.283	1.89
1.3/8	1622DS	2.677	2.125	0.826	1.220	2.401	1.98
1.7/16	1623DS	2.795	2.125	0.984	1.220	2.401	2.02
1.1/2	1624DS	2.913	2.125	0.984	1.377	2.559	2.53
1.9/16	1625DS	2.834	2.125	0.984	1.377	2.559	2.55
1.5/8	1626DS	3.031	2.125	1.102	1.377	2.559	2.55
1.11/16	1627DS	3.149	2.125	1.102	1.574	2.755	3.30
1.3/4	1628DS	3.267	2.125	1.102	1.574	2.755	3.30
1.13/16	1629DS	3.385	2.125	1.102	1.574	2.755	3.52
1.7/8	1630DS	3.503	2.125	1.102	1.574	2.755	3.52
2	1632DS	3.661	2.125	1.102	1.692	2.874	3.96
2.1/16	1633DS	3.779	2.125	1.102	1.692	2.874	4.95
2.1/8	1634DS	3.779	2.125	1.102	1.850	3.031	4.95
2.3/16	1635DS	3.937	2.125	1.181	1.850	3.031	6.49
2.1/4	1636DS	4.055	3.385	1.181	2.007	3.188	6.49
2.3/8	1638DS	4.173	3.385	1.259	2.086	3.267	7.04
2.1/2	1640DS	4.409	3.385	1.259	2.204	3.385	8.47

## METRIC DEEP BISQUARE

A/F mm	MODEL NO.	D1 mm	D2 mm	T mm	C mm	OAL mm	Wt. Kg.
32	16M32LDS	65.0	54.0	21.0	80.0	110.0	1.46
33	16M33LDS	65.0	54.0	21.0	80.0	110.0	1.46
34	16M34LDS	68.0	54.0	21.0	80.0	110.0	1.50
35	16M35LDS	68.0	54.0	21.0	80.0	110.0	1.50
36	16M36LDS	71.0	54.0	25.0	80.0	110.0	1.52
38	16M38LDS	74.0	54.0	25.0	80.0	110.0	1.75
39	16M39LDS	74.0	54.0	25.0	80.0	110.0	1.75
40	16M40LDS	77.0	54.0	25.0	80.0	110.0	1.76
41	16M41LDS	77.0	54.0	28.0	80.0	110.0	1.76
42	16M42LDS	80.0	54.0	28.0	80.0	110.0	1.96
43	16M43LDS	80.0	54.0	28.0	80.0	110.0	2.16
46	16M46LDS	86.0	54.0	28.0	80.0	110.0	2.30
50	16M50LDS	90.0	54.0	28.0	80.0	110.0	2.50
51	16M51LDS	93.0	54.0	28.0	80.0	110.0	2.60
54	16M54LDS	98.0	54.0	28.0	80.0	110.0	2.95
55	16M55LDS	98.0	54.0	30.0	80.0	110.0	2.95
57	16M57LDS	103.0	86.0	30.0	80.0	110.0	3.65
60	16M60LDS	106.0	86.0	32.0	100.0	130.0	4.00
65	16M65LDS	112.0	86.0	38.0	100.0	130.0	4.55

## FRACTIONAL DEEP BISQUARE

A/F inch	MODEL NO.	D1 inch	D2 inch	T inch	C inch	OAL inch	Wt. lbs.
1.1/4	1620LDS	2.559	2.125	0.826	3.149	4.330	3.21
1.5/16	1621LDS	2.559	2.125	0.826	3.149	4.330	3.21
1.3/8	1622LDS	2.677	2.125	0.826	3.149	4.330	3.30
1.7/16	1623LDS	2.795	2.125	0.984	3.149	4.330	3.34
1.1/2	1624LDS	2.913	2.125	0.984	3.149	4.330	3.85
1.9/16	1625LDS	2.834	2.125	0.984	3.149	4.330	3.87
1.5/8	1626LDS	3.031	2.125	1.102	3.149	4.330	3.87
1.11/16	1627LDS	3.149	2.125	1.102	3.149	4.330	4.75
1.3/4	1628LDS	3.267	2.125	1.102	3.149	4.330	4.84
1.13/16	1629LDS	3.385	2.125	1.102	3.149	4.330	5.06
1.7/8	1630LDS	3.503	2.125	1.102	3.149	4.330	5.28
2	1632LDS	3.661	2.125	1.102	3.149	4.330	5.72
2.1/16	1633LDS	3.779	2.125	1.102	3.149	4.330	6.49
2.1/8	1634LDS	3.779	2.125	1.102	3.149	4.330	6.49
2.3/16	1635LDS	3.937	2.125	1.181	3.149	4.330	8.03
2.1/4	1636LDS	4.055	3.385	1.181	3.149	4.330	8.03
2.3/8	1638LDS	4.173	3.385	1.259	3.937	5.118	8.80
2.1/2	1640LDS	4.409	3.385	1.259	3.937	5.118	10.01

# IMPACT SOCKETS THINWALL



## METRIC HEXAGON



A/F mm	MODEL NO.	D1 mm	D2 mm	T mm	C mm	OAL mm	Wt. Kg.
22	S-16M22T	35.6	51.0	14.0	25.0	55.0	0.48
23	S-16M23T	37.0	51.0	14.0	25.0	55.0	0.48
24	S-16M24T	38.0	51.0	16.0	27.0	57.0	0.50
25	S-16M25T	39.5	51.0	16.0	27.0	57.0	0.50
26	S-16M26T	40.8	51.0	16.0	27.0	57.0	0.51
27	S-16M27T	42.0	51.0	16.0	27.0	57.0	0.52
28	S-16M28T	43.3	51.0	16.0	27.0	57.0	0.52
29	S-16M29T	44.5	51.0	18.0	29.0	59.0	0.54
30	S-16M30T	45.9	51.0	18.0	29.0	59.0	0.55
31	S-16M31T	47.0	51.0	18.0	29.0	59.0	0.55
32	S-16M32T	48.3	51.0	18.0	29.0	59.0	0.56
33	S-16M33T	49.5	51.0	18.0	29.0	59.0	0.56
34	S-16M34T	51.0	51.0	20.0	31.0	61.0	0.59
35	S-16M35T	52.0	54.0	20.0	31.0	61.0	0.65
36	S-16M36T	53.4	54.0	20.0	31.0	61.0	0.69
37	S-16M37T	54.0	54.0	20.0	31.0	61.0	0.69
38	S-16M38T	55.9	54.0	22.0	34.0	64.0	0.75
39	S-16M39T	57.1	54.0	22.0	34.0	64.0	0.78
40	S-16M40T	58.1	54.0	22.0	34.0	64.0	0.79
41	S-16M41T	59.9	54.0	22.0	34.0	64.0	0.82
42	S-16M42T	60.9	54.0	24.0	36.0	66.0	0.85
43	S-16M43T	62.0	54.0	24.0	36.0	66.0	0.86
44	S-16M44T	63.4	54.0	24.0	36.0	66.0	0.88
45	S-16M45T	64.6	54.0	24.0	36.0	66.0	0.89
46	S-16M46T	65.9	54.0	26.0	38.0	68.0	0.93

## FRACTIONAL HEXAGON



A/F inch	MODEL NO.	D1 inch	D2 inch	T inch	C inch	OAL inch	Wt. lbs.
7/8	S-1614T	1.457	2.008	0.551	0.984	2.165	1.06
15/16	S-1615T	1.508	2.008	0.630	1.063	2.244	1.10
1	S-1616T	1.606	2.008	0.630	1.063	2.244	1.12
1.1/16	S-1617T	1.654	2.008	0.630	1.063	2.244	1.13
1.1/8	S-1618T	1.752	2.008	0.709	1.142	2.323	1.18
1.3/16	S-1619T	1.850	2.008	0.709	1.142	2.323	1.21
1.1/4	S-1620T	1.902	2.008	0.709	1.142	2.323	1.23
1.5/16	S-1621T	2.008	2.008	0.787	1.220	2.402	1.29
1.3/8	S-1622T	2.047	2.126	0.787	1.220	2.402	1.44
1.7/16	S-1623T	2.126	2.126	0.787	1.220	2.402	1.51
1.1/2	S-1624T	2.201	2.126	0.866	1.339	2.520	1.65
1.9/16	S-1625T	2.287	2.126	0.866	1.339	2.520	1.73
1.5/8	S-1626T	2.398	2.126	0.945	1.417	2.598	1.87
1.11/16	S-1627T	2.437	2.126	0.945	1.417	2.598	1.89
1.3/4	S-1628T	2.543	2.126	0.945	1.417	2.598	1.97
1.13/16	S-1629T	2.594	2.126	1.024	1.496	2.677	2.05

## METRIC DEEP HEXAGON



A/F mm	MODEL NO.	D1 mm	D2 mm	T mm	C mm	OAL mm	Wt. Kg.
22	S-16M22LT	35.6	54.0	14.0	80.0	110.0	1.05
23	S-16M23LT	37.0	54.0	14.0	80.0	110.0	1.05
24	S-16M24LT	38.3	54.0	16.0	80.0	110.0	1.05
25	S-16M25LT	39.5	54.0	16.0	80.0	110.0	1.10
26	S-16M26LT	40.8	54.0	16.0	80.0	110.0	1.10
27	S-16M27LT	42.0	54.0	16.0	80.0	110.0	1.10
28	S-16M28LT	43.3	54.0	16.0	80.0	110.0	1.15
29	S-16M29LT	44.5	54.0	16.0	80.0	110.0	1.15
30	S-16M30LT	45.9	54.0	21.0	80.0	110.0	1.22
31	S-16M31LT	47.0	54.0	21.0	80.0	110.0	1.21
32	S-16M32LT	48.3	54.0	21.0	80.0	110.0	1.25
33	S-16M33LT	49.5	54.0	21.0	80.0	110.0	1.27
34	S-16M34LT	50.8	54.0	21.0	80.0	110.0	1.30
35	S-16M35LT	52.0	54.0	21.0	80.0	110.0	1.30
36	S-16M36LT	53.4	54.0	25.0	80.0	110.0	1.30
37	S-16M37LT	54.0	54.0	25.0	80.0	110.0	1.45
38	S-16M38LT	55.9	54.0	25.0	80.0	110.0	1.50
39	S-16M39LT	57.1	54.0	25.0	80.0	110.0	1.60
40	S-16M40LT	58.1	54.0	25.0	80.0	110.0	1.60
41	S-16M41LT	59.9	54.0	28.0	80.0	110.0	1.60
42	S-16M42LT	60.9	54.0	28.0	80.0	110.0	1.65
43	S-16M43LT	61.9	54.0	28.0	80.0	110.0	1.70
44	S-16M44LT	63.4	54.0	28.0	80.0	110.0	1.70
45	S-16M45LT	64.6	54.0	28.0	80.0	110.0	1.70
46	S-16M46LT	65.9	54.0	28.0	80.0	110.0	2.15

## FRACTIONAL DEEP HEXAGON



A/F inch	MODEL NO.	D1 inch	D2 inch	T inch	C inch	OAL inch	Wt. lbs.
7/8	S-1614LT	1.417	2.125	0.629	3.149	4.330	2.21
15/16	S-1615LT	1.507	2.125	0.629	3.149	4.330	2.21
1	S-1616LT	1.574	2.125	0.629	3.149	4.330	2.42
1.1/16	S-1617LT	1.653	2.125	0.629	3.149	4.330	2.53
1.1/8	S-1618LT	1.728	2.125	0.629	3.149	4.330	2.53
1.3/16	S-1619LT	1.807	2.125	0.826	3.149	4.330	2.70
1.1/4	S-1620LT	1.889	2.125	0.826	3.149	4.330	2.75
1.5/16	S-1621LT	1.968	2.125	0.826	3.149	4.330	2.95
1.3/8	S-1622LT	2.047	2.125	0.826	3.149	4.330	2.86
1.7/16	S-1623LT	2.125	2.125	0.984	3.149	4.330	3.22
1.1/2	S-1624LT	2.200	2.125	0.984	3.149	4.330	3.30
1.9/16	S-1625LT	2.283	2.125	0.984	3.149	4.330	3.52
1.5/8	S-1626LT	2.358	2.125	1.102	3.149	4.330	3.52
1.11/16	S-1627LT	2.437	2.125	1.102	3.149	4.330	3.52
1.3/4	S-1628LT	2.519	2.125	1.102	3.149	4.330	3.74
1.13/16	S-1629LT	2.594	2.125	1.102	3.149	4.330	3.74





# IMPACT ACCESSORIES

## METRIC HEX DRIVER SOCKETS

HEX A/F mm	MODEL NO.	BIT LENGTH	OAL mm	Wt Kg.
10	16M10H	20.0	85.0	0.60
12	16M12H	25.0	90.0	0.65
14	16M14H	25.0	90.0	0.75
17	16M17H	30.0	95.0	0.80
19	16M19H	30.0	95.0	0.80
22	16M22H	45.0	115.0	0.90
24	16M24H	45.0	115.0	0.95
27	16M27H	50.0	120.0	1.15
30	16M30H	50.0	120.0	1.20
32	16M32H	50.0	120.0	1.30
36	16M36H	50.0	120.0	1.30

## FRACTIONAL HEX DRIVE SOCKETS

HEX A/F inch	MODEL NO	BIT LENGTH	OAL inch	Wt lbs.
1/2	1608H	0.984	3.543	1.43
9/16	1609H	0.984	3.543	1.65
5/8	1610H	1.181	3.740	1.65
3/4	1612H	1.181	3.740	1.76
13/16	1613H	1.771	4.527	1.87
7/8	1614H	1.771	4.527	1.98
1	1616H	1.968	4.724	2.20
1.1/16	1617H	1.968	4.724	2.20
1.1/8	1618H	1.968	4.724	2.42
1.3/16	1619H	1.968	4.724	2.64
1.1/4	1620H	1.968	4.724	2.86

## REGULAR EXTENSIONS

OAL mm (inch)	MODEL NO.	SHANK DIA mm (inch)	HEAD DIA mm (inch)	Wt Kg. (lbs.)
100 (4")	E1604	36.0 (1.417)	54.0 (2.125)	1.10 (2.42)
125 (5")	E1605			1.30 (2.86)
150 (6")	E1606			1.50 (3.30)
180 (7")	E1607	36.0 (1.417)	54.0 (2.125)	1.75 (3.85)
250 (10")	E1610			2.00 (4.40)
330 (13")	E1613			2.45 (5.39)



## SQUARE ADAPTORS

SIZE	MODEL NO.	HEAD DIA mm (inch)	OAL mm (inch)	Wt Kg. (lbs.)
1" F X 3/4" M	A1612	54.0 (2.125)	70.0 (2.755)	0.64 (1.40)
1" F X 1.1/2" M	A1624		90.0 (3.543)	0.90 (1.98)
1" F X #5 M	A1695		110.0 (4.330)	1.20 (2.64)



## UNIVERSAL JOINT

SQUARE DRIVE	MODEL NO.	DIA mm (inch)	OAL mm (inch)	Wt Kg. (lbs.)
1"	U1616	54.0 (2.125)	117.0 (4.606)	1.20 (2.64)



## DOUBLE MALE EXTENSIONS

OAL mm (inch)	MODEL NO.	SHANK DIA mm (inch)	HEAD DIA mm (inch)	Wt Kg. (lbs.)
75 (3")	S1603	35.0 (1.377)	25.0 (1.000)	0.70 (1.54)
125 (5")	S1605			1.00 (2.20)
180 (7")	S1607			1.45 (3.19)
250 (10")	S1610	35.0 (1.377)	25.0 (1.000)	1.70 (3.74)
330 (13")	S1613			2.20 (4.84)
380 (15")	S1615	35.0 (1.377)	25.0 (1.000)	2.50 (5.50)
430 (17")	S1617			3.00 (6.60)



## DOUBLE FEMALE ADAPTORS

SIZE	MODEL NO.	HEAD DIA mm (inch)	OAL mm (inch)	Wt Kg. (lbs.)
1" F X 3/4" F	AN1612	54.0 (2.125)	65.0 (2.559)	0.75 (1.65)
1" F X 1" F	AN1616		70.0 (2.755)	0.95 (2.09)
1" F X 1.1/2" F	AN1624		80.0 (3.149)	1.10 (2.42)





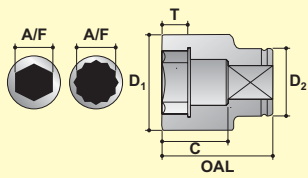

**A/F** Nominal size across flats  
**D1** Max. outside dia. socket end  
**D2** Max. outside dia. sq. drive end  
**OAL** Nominal overall length  
**T** Min. depth of socket form  
**C** Bolt clearance depth

# IMPACT SOCKETS

1 1/2"



## METRIC HEXAGON



## FRACTIONAL HEXAGON



A/F mm	MODEL NO.	D1 mm	D2 mm	T mm	C mm	OAL mm	Wt. Kg.
32	S-24M32	58.0	82.0	19.0	33.0	75.0	1.91
33	S-24M33	59.0	82.0	19.0	33.0	75.0	1.91
34	S-24M34	60.0	82.0	20.0	33.0	75.0	1.91
35	S-24M35	62.0	82.0	21.0	35.0	77.0	1.97
36	S-24M36	63.0	82.0	21.0	35.0	77.0	1.97
37	S-24M37	64.0	82.0	21.0	35.0	77.0	1.97
38	S-24M38	65.0	84.0	21.0	35.0	77.0	2.07
39	S-24M39	67.0	84.0	22.0	36.0	78.0	2.12
40	S-24M40	68.0	84.0	22.0	36.0	78.0	2.13
41	S-24M41	69.0	84.0	23.0	37.0	79.0	2.14
42	S-24M42	70.0	84.0	23.0	37.0	79.0	2.15
43	S-24M43	71.0	84.0	24.0	38.0	80.0	2.17
44	S-24M44	73.0	84.0	24.0	38.0	80.0	2.20
45	S-24M45	74.0	84.0	25.0	39.0	81.0	2.22
46	S-24M46	75.0	86.0	26.0	40.0	82.0	2.35
47	S-24M47	77.0	86.0	26.0	40.0	82.0	2.38
48	S-24M48	78.0	86.0	26.0	40.0	82.0	2.39
49	S-24M49	79.0	86.0	27.0	41.0	83.0	2.41
50	S-24M50	80.0	86.0	27.0	41.0	83.0	2.42
51	S-24M51	81.0	86.0	27.0	41.0	83.0	2.42
52	S-24M52	82.0	86.0	28.0	42.0	84.0	2.45
54	S-24M54	84.0	86.0	28.0	42.0	84.0	2.47
55	S-24M55	86.0	86.0	29.0	43.0	85.0	2.52
56	S-24M56	88.0	86.0	29.0	43.0	85.0	2.71
57	S-24M57	88.0	86.0	29.0	43.0	85.0	2.67
58	S-24M58	90.0	86.0	30.0	44.0	86.0	2.78
59	S-24M59	90.0	86.0	32.0	46.0	88.0	2.75
60	S-24M60	90.0	86.0	32.0	46.0	88.0	2.75
61	S-24M61	94.0	86.0	32.0	46.0	88.0	2.92
62	S-24M62	94.0	86.0	32.0	46.0	88.0	2.92
65	S-24M65	98.0	86.0	34.0	48.0	90.0	3.09
67	S-24M67	101.0	86.0	36.0	50.0	92.0	3.26
70	S-24M70	104.0	86.0	38.0	53.0	95.0	3.40
73	S-24M73	108.0	86.0	40.0	55.0	97.0	3.71
75	S-24M75	111.0	86.0	42.0	59.0	101.0	4.04
76	S-24M76	118.0	86.0	44.0	61.0	103.0	4.41
80	S-24M80	118.0	86.0	44.0	61.0	103.0	4.41
85	S-24M85	124.0	86.0	48.0	66.0	108.0	4.88
86	S-24M86	124.0	86.0	50.0	68.0	110.0	4.82
90	S-24M90	130.0	106.0	53.0	71.0	113.0	6.24
95	S-24M95	135.0	106.0	56.0	74.0	116.0	6.56
100	S-24M100	143.0	106.0	59.0	77.0	119.0	7.48
105	S-24M105	148.0	106.0	62.0	82.0	124.0	7.93
110	S-24M110	154.0	106.0	65.0	85.0	127.0	8.51
115	S-24M115	161.0	127.0	68.0	88.0	130.0	10.48
120	S-24M120	168.0	127.0	71.0	91.0	133.0	11.38
125	S-24M125	174.0	127.0	74.0	96.0	138.0	12.31
130	S-24M130	180.0	127.0	77.0	99.0	141.0	13.09

A/F inch	MODEL NO.	D1 inch	D2 inch	T inch	C inch	OAL inch	Wt. lbs.
1.3/8	S-2422	2.441	3.228	0.827	1.378	3.031	4.30
1.7/16	S-2423	2.520	3.228	0.827	1.378	3.031	4.30
1.1/2	S-2424	2.559	3.307	0.827	1.378	3.031	4.60
1.9/16	S-2425	2.677	3.307	0.866	1.417	3.071	4.70
1.5/8	S-2426	2.717	3.307	0.906	1.457	3.110	4.70
1.11/16	S-2427	2.795	3.307	0.945	1.496	3.150	4.80
1.3/4	S-2428	2.913	3.307	0.984	1.535	3.189	4.90
1.13/16	S-2429	2.953	3.386	1.024	1.575	3.228	5.20
1.7/8	S-2430	3.071	3.386	1.024	1.575	3.228	5.30
1.15/16	S-2431	3.110	3.386	1.063	1.614	3.268	5.30
2	S-2432	3.189	3.386	1.063	1.614	3.268	5.30
2.1/16	S-2433	3.228	3.386	1.102	1.654	3.307	5.40
2.1/8	S-2434	3.307	3.386	1.102	1.654	3.307	5.40
2.3/16	S-2435	3.465	3.386	1.142	1.693	3.346	6.00
2.1/4	S-2436	3.465	3.386	1.142	1.693	3.346	5.90
2.5/16	S-2437	3.543	3.386	1.181	1.732	3.386	6.10
2.3/8	S-2438	3.543	3.386	1.260	1.811	3.465	6.10
2.7/16	S-2439	3.701	3.386	1.260	1.811	3.465	6.40
2.1/2	S-2440	3.751	3.386	1.260	1.811	3.465	7.30
2.9/16	S-2441	3.858	3.386	1.339	1.890	3.543	6.80
2.5/8	S-2442	3.976	3.386	1.417	1.969	3.622	7.20
2.11/16	S-2443	4.026	3.386	1.417	1.969	3.622	7.40
2.3/4	S-2444	4.094	3.386	1.496	2.087	3.740	7.50
2.13/16	S-2445	4.144	3.386	1.496	2.087	3.740	8.30
2.7/8	S-2446	4.252	3.386	1.575	2.165	3.819	8.20
2.15/16	S-2447	4.372	3.386	1.654	2.323	3.976	8.90
3	S-2448	4.420	3.386	1.654	2.323	3.976	9.80
3.1/16	S-2449	4.646	3.386	1.732	2.402	4.055	9.70
3.1/8	S-2450	4.646	3.386	1.732	2.402	4.055	9.70
3.3/16	S-2451	4.716	3.386	1.732	2.402	4.055	10.70
3.1/4	S-2452	4.716	3.386	1.732	2.402	4.055	10.70
3.5/16	S-2453	4.882	3.386	1.969	2.677	4.331	10.60
3.3/8	S-2454	4.882	3.386	1.969	2.677	4.331	10.60
3.7/16	S-2455	5.118	4.173	2.087	2.795	4.449	13.70
3.1/2	S-2456	5.118	4.173	2.087	2.795	4.449	13.70
3.9/16	S-2457	5.193	4.173	2.087	2.795	4.449	13.80
3.5/8	S-2458	5.193	4.173	2.087	2.795	4.449	13.80
3.11/16	S-2459	5.315	4.173	2.205	2.913	4.567	17.00
3.3/4	S-2460	5.315	4.173	2.205	2.913	4.567	17.00
3.13/16	S-2461	5.670	4.173	2.323	3.031	4.685	17.00
3.7/8	S-2462	5.670	4.173	2.323	3.031	4.685	17.00
3.15/16	S-2463	5.745	4.173	2.323	3.031	4.685	17.90
4	S-2464	5.745	4.173	2.323	3.031	4.685	17.90
4.1/16	S-2465	5.827	4.173	2.441	3.228	4.882	17.40
4.1/8	S-2466	5.827	4.173	2.441	3.228	4.882	17.40
4.3/16	S-2467	6.103	4.173	2.559	3.346	5.000	18.70
4.1/4	S-2468	6.103	4.173	2.559	3.346	5.000	18.70
4.3/8	S-2470	6.193	4.173	2.559	3.346	5.000	19.70
4.1/2	S-2472	6.339	5.000	2.677	3.465	5.118	23.00
4.5/8	S-2474	6.419	5.000	2.677	3.465	5.118	24.20
4.3/4	S-2476	6.614	5.000	2.795	3.583	5.236	25.00
5	S-2480	6.930	5.000	2.913	3.780	5.433	28.30
5.1/8	S-2482	7.087	5.000	3.031	3.898	5.551	28.80

1 1/2"

**IMPACT SOCKETS**

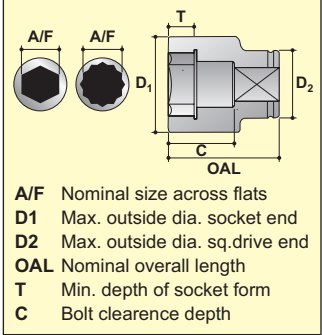

**METRIC DEEP HEXAGON**

**FRACTIONAL DEEP HEXAGON**

A/F mm	MODEL NO.	D1 mm	D2 mm	T mm	C mm	OAL mm	Wt. Kg.
32	S-24M32L	58.0	82.0	19.0	78.0	120.0	2.55
33	S-24M33L	59.0	82.0	19.0	78.0	120.0	2.57
34	S-24M34L	60.0	82.0	20.0	78.0	120.0	2.58
35	S-24M35L	62.0	82.0	21.0	78.0	120.0	2.65
36	S-24M36L	63.0	82.0	21.0	78.0	120.0	2.67
37	S-24M37L	64.0	82.0	21.0	78.0	120.0	2.69
38	S-24M38L	65.0	82.0	21.0	78.0	120.0	2.70
39	S-24M39L	67.0	84.0	22.0	78.0	120.0	2.91
40	S-24M40L	68.0	84.0	22.0	78.0	120.0	2.92
41	S-24M41L	69.0	84.0	23.0	83.0	125.0	3.03
42	S-24M42L	70.0	84.0	23.0	83.0	125.0	3.05
43	S-24M43L	71.0	84.0	24.0	83.0	125.0	3.07
44	S-24M44L	73.0	84.0	24.0	83.0	125.0	3.16
45	S-24M45L	74.0	84.0	25.0	83.0	125.0	3.17
46	S-24M46L	75.0	86.0	26.0	83.0	125.0	3.30
47	S-24M47L	77.0	86.0	26.0	83.0	125.0	3.39
48	S-24M48L	78.0	86.0	26.0	83.0	125.0	3.41
49	S-24M49L	79.0	86.0	27.0	83.0	125.0	3.42
50	S-24M50L	80.0	86.0	27.0	83.0	125.0	3.44
51	S-24M51L	81.0	86.0	27.0	83.0	125.0	3.46
52	S-24M52L	82.0	86.0	28.0	88.0	130.0	3.64
54	S-24M54L	84.0	86.0	28.0	88.0	130.0	3.67
55	S-24M55L	86.0	86.0	29.0	88.0	130.0	3.80
56	S-24M56L	88.0	86.0	29.0	88.0	130.0	4.12
57	S-24M57L	88.0	86.0	29.0	88.0	130.0	4.05
58	S-24M58L	90.0	86.0	30.0	88.0	130.0	4.20
59	S-24M59L	90.0	86.0	32.0	88.0	130.0	4.04
60	S-24M60L	90.0	86.0	32.0	88.0	130.0	4.04
61	S-24M61L	94.0	86.0	32.0	88.0	130.0	4.35
62	S-24M62L	94.0	86.0	32.0	88.0	130.0	4.35
65	S-24M65L	99.0	86.0	34.0	98.0	140.0	5.05
67	S-24M67L	101.0	86.0	36.0	98.0	140.0	5.11
70	S-24M70L	104.0	86.0	38.0	98.0	140.0	5.23
73	S-24M73L	109.0	86.0	40.0	98.0	140.0	5.73
75	S-24M75L	111.0	86.0	42.0	108.0	150.0	6.27
76	S-24M76L	118.0	86.0	44.0	108.0	150.0	6.82
80	S-24M80L	118.0	86.0	44.0	108.0	150.0	6.82
85	S-24M85L	124.0	86.0	48.0	118.0	160.0	7.79
86	S-24M86L	124.0	86.0	50.0	118.0	160.0	7.57
90	S-24M90L	130.0	106.0	53.0	128.0	170.0	9.68
95	S-24M95L	135.0	106.0	56.0	128.0	170.0	9.97
100	S-24M100L	143.0	106.0	59.0	128.0	170.0	11.03
105	S-24M105L	148.0	106.0	62.0	138.0	180.0	11.99
110	S-24M110L	154.0	106.0	65.0	138.0	180.0	12.61
115	S-24M115L	161.0	127.0	68.0	138.0	180.0	14.69
120	S-24M120L	167.0	127.0	71.0	148.0	190.0	16.25
125	S-24M125L	174.0	127.0	74.0	148.0	190.0	17.35
130	S-24M130L	180.0	127.0	77.0	148.0	190.0	18.11

A/F inch	MODEL NO.	D1 inch	D2 inch	T inch	C inch	OAL inch	Wt. lbs.
1.3/8	S-2422L	2.441	3.228	0.827	3.071	4.724	5.80
1.7/16	S-2423L	2.520	3.228	0.827	3.071	4.724	5.90
1.1/2	S-2424L	2.559	3.228	0.827	3.071	4.724	5.90
1.9/16	S-2425L	2.677	3.307	0.866	3.071	4.724	6.40
1.5/8	S-2426L	2.717	3.307	0.906	3.268	4.921	6.70
1.11/16	S-2427L	2.795	3.307	0.945	3.268	4.921	6.80
1.3/4	S-2428L	2.913	3.307	0.984	3.268	4.921	7.00
1.13/16	S-2429L	2.953	3.386	1.024	3.268	4.921	7.30
1.7/8	S-2430L	3.071	3.386	1.024	3.268	4.921	7.50
1.15/16	S-2431L	3.110	3.386	1.063	3.268	4.921	7.50
2	S-2432L	3.189	3.386	1.063	3.268	4.921	7.60
2.1/16	S-2433L	3.228	3.386	1.102	3.465	5.118	8.00
2.1/8	S-2434L	3.307	3.386	1.102	3.465	5.118	8.10
2.3/16	S-2435L	3.465	3.386	1.142	3.465	5.118	9.10
2.1/4	S-2436L	3.465	3.386	1.142	3.465	5.118	8.90
2.5/16	S-2437L	3.543	3.386	1.181	3.465	5.118	9.20
2.3/8	S-2438L	3.543	3.386	1.260	3.465	5.118	8.90
2.7/16	S-2439L	3.701	3.386	1.260	3.465	5.118	9.60
2.1/2	S-2440L	3.751	3.386	1.260	3.465	5.118	10.50
2.9/16	S-2441L	3.898	3.386	1.339	3.858	5.512	11.10
2.5/8	S-2442L	3.976	3.386	1.417	3.858	5.512	11.20
2.11/16	S-2443L	4.026	3.386	1.417	3.858	5.512	11.40
2.3/4	S-2444L	4.094	3.386	1.496	3.858	5.512	11.50
2.13/16	S-2445L	4.144	3.386	1.496	3.858	5.512	12.30
2.7/8	S-2446L	4.291	3.386	1.575	3.858	5.512	12.60
2.15/16	S-2447L	4.370	3.386	1.654	4.252	5.906	13.80
3	S-2448L	4.420	3.386	1.654	4.252	5.906	14.70
3.1/16	S-2449L	4.646	3.386	1.732	4.252	5.906	15.00
3.1/8	S-2450L	4.646	3.386	1.732	4.252	5.906	15.00
3.3/16	S-2451L	4.716	3.386	1.732	4.252	5.906	16.00
3.1/4	S-2452L	4.716	3.386	1.732	4.252	5.906	16.00
3.5/16	S-2453L	4.882	3.386	1.969	4.646	6.299	16.70
3.3/8	S-2454L	4.882	3.386	1.969	4.646	6.299	16.70
3.7/16	S-2455L	5.118	4.173	2.087	5.039	6.693	21.30
3.1/2	S-2456L	5.118	4.173	2.087	5.039	6.693	21.30
3.9/16	S-2457L	5.193	4.173	2.087	5.039	6.693	21.40
3.5/8	S-2458L	5.193	4.173	2.087	5.039	6.693	21.40
3.11/16	S-2459L	5.315	4.173	2.205	5.039	6.693	21.90
3.3/4	S-2460L	5.315	4.173	2.205	5.039	6.693	21.90
3.13/16	S-2461L	5.670	4.173	2.323	5.039	6.693	24.90
3.7/8	S-2462L	5.670	4.173	2.323	5.039	6.693	24.90
3.15/16	S-2463L	5.745	4.173	2.323	5.039	6.693	25.80
4	S-2464L	5.745	4.173	2.323	5.039	6.693	25.80
4.1/16	S-2465L	5.827	4.173	2.441	5.433	7.087	26.40
4.1/8	S-2466L	5.827	4.173	2.441	5.433	7.087	26.40
4.3/16	S-2467L	6.103	4.173	2.559	5.433	7.087	27.70
4.1/4	S-2468L	6.103	4.173	2.559	5.433	7.087	27.70
4.3/8	S-2470L	6.193	4.173	2.559	5.433	7.087	28.70
4.1/2	S-2472L	6.339	5.000	2.677	5.433	7.087	32.30
4.5/8	S-2474L	6.575	5.000	2.795	5.827	7.480	35.70
4.3/4	S-2476L	6.575	5.000	2.795	5.827	7.480	35.70
5	S-2480L	6.930	5.000	2.913	5.827	7.480	39.40
5.1/8	S-2482L	7.087	5.000	3.031	5.827	7.480	39.90

## REGULAR EXTENSIONS

OAL mm (inch)	MODEL NO.	SHANK DIA mm (inch)	HEAD DIA mm (inch)	Wt Kg. (lbs.)
150 (6") 304 (12")	E2406 E2412	52.0 (2.047)	86.0 (3.386)	3.90 (8.58) 6.30 (13.86)



## DOUBLE MALE EXTENSIONS

OAL mm (inch)	MODEL NO.	SHANK DIA mm (inch)	HEAD DIA mm (inch)	Wt Kg. (lbs.)
100 (4") 125 (5") 250 (10") 510 (20")	S2404 S2405 S2410 S2420	52.0 (2.047)	38.1 (1.500)	2.50 (5.50) 2.80 (6.16) 3.60 (7.92) 5.10 (11.20)



## SQUARE ADAPTORS

SIZE	MODEL NO.	HEAD DIA mm (inch)	OAL mm (inch)	Wt Kg. (lbs.)
1.1/2" F X 1" M	A2416	86.0 (3.386)	100.0 (3.937)	1.98 (4.37)
1.1/2" F X 2.1/2" M	A2440	86.0 (3.386)	113.0 (4.448)	3.92 (8.65)
1.1/2" F X #5 M	A2495	86.0 (3.386)	115.0 (4.527)	4.20 (9.25)



## DOUBLE FEMALE ADAPTORS

SIZE	MODEL NO.	HEAD DIA mm (inch)	OAL mm (inch)	Wt Kg. (lbs.)
1.1/2" F X 1" F	AN2416	86.0 (3.386)	80.0 (3.149)	2.30 (5.06)
1.1/2" F X 1.1/2" F	AN2424	86.0 (3.386)	95.0 (3.740)	3.60 (7.92)
1.1/2" F X 2.1/2" F	AN2440	86.0 (3.386)	110.0 (4.330)	4.50 (9.90)



## UNIVERSAL JOINT

SQUARE DRIVE	MODEL NO.	DIA mm (inch)	OAL mm (inch)	Wt Kg. (lbs.)
1.1/2"	U2424	86.0 (3.386)	158 (6.220)	3.85 (8.47)



POWERMASTER AMERICA Impact Sockets  
ideal for use with Hydraulic Torque Wrenches.



2 1/2"

**IMPACT SOCKETS**

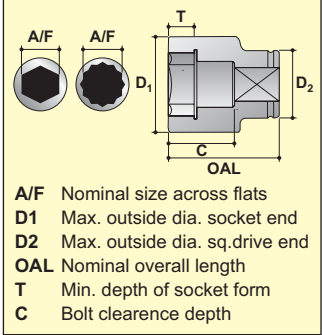

**METRIC HEXAGON**

**FRACTIONAL HEXAGON**

A/F mm	MODEL NO.	D1 mm	D2 mm	T mm	C mm	OAL mm	Wt. Kg.
43	S-40M43	86.0	116.0	28.0	46.0	104.0	5.24
44	S-40M44	86.0	116.0	28.0	46.0	104.0	5.20
45	S-40M45	86.0	116.0	28.0	46.0	104.0	5.15
46	S-40M46	86.0	116.0	28.0	46.0	104.0	5.11
47	S-40M47	86.0	116.0	28.0	46.0	104.0	5.06
48	S-40M48	86.0	116.0	28.0	46.0	104.0	5.01
49	S-40M49	86.0	116.0	28.0	46.0	104.0	4.97
50	S-40M50	86.1	116.0	28.0	46.0	104.0	4.92
51	S-40M51	90.0	116.0	29.0	46.0	104.0	5.07
52	S-40M52	90.0	116.0	29.0	46.0	104.0	5.02
54	S-40M54	92.5	124.0	30.0	46.0	104.0	5.87
55	S-40M55	93.8	124.0	32.0	52.0	110.0	6.08
56	S-40M56	95.0	124.0	32.0	52.0	110.0	6.10
57	S-40M57	96.3	124.0	32.0	52.0	110.0	6.12
58	S-40M58	97.5	124.0	32.0	52.0	110.0	6.14
59	S-40M59	98.8	127.0	34.0	54.0	112.0	6.55
60	S-40M60	100.0	127.0	36.0	56.0	114.0	6.64
62	S-40M62	103.0	127.0	36.0	56.0	114.0	6.69
65	S-40M65	106.0	127.0	38.0	58.0	116.0	6.83
67	S-40M67	109.0	127.0	38.0	58.0	116.0	6.89
70	S-40M70	113.0	127.0	40.0	60.0	118.0	7.05
73	S-40M73	116.0	127.0	40.0	60.0	118.0	7.13
75	S-40M75	119.0	127.0	42.0	64.0	122.0	7.38
76	S-40M76	120.0	127.0	44.0	64.0	122.0	7.39
80	S-40M80	125.0	127.0	44.0	64.0	122.0	7.50
85	S-40M85	129.0	127.0	48.0	68.0	126.0	8.06
86	S-40M86	132.0	127.0	50.0	68.0	129.0	8.59
90	S-40M90	136.0	127.0	52.0	70.0	130.0	8.87
95	S-40M95	142.0	127.0	54.0	72.0	132.0	9.37
100	S-40M100	148.0	127.0	56.0	78.0	138.0	10.20
105	S-40M105	154.0	127.0	60.0	82.0	142.0	10.99
110	S-40M110	161.0	127.0	64.0	86.0	146.0	11.89
115	S-40M115	165.0	127.0	67.0	89.0	149.0	12.19
120	S-40M120	173.0	127.0	70.0	92.0	152.0	13.30
125	S-40M125	179.0	127.0	73.0	95.0	153.0	13.68
130	S-40M130	185.0	127.0	76.0	98.0	156.0	14.52
135	S-40M135	192.0	152.0	79.0	103.0	161.0	18.37
140	S-40M140	196.0	152.0	82.0	106.0	164.0	18.58
145	S-40M145	204.0	152.0	85.0	109.0	167.0	20.22
150	S-40M150	211.0	152.0	88.0	112.0	170.0	21.37
155	S-40M155	215.0	152.0	91.0	117.0	175.0	22.04
160	S-40M160	223.0	152.0	94.0	120.0	178.0	23.92
165	S-40M165	229.0	175.0	96.0	122.0	180.0	27.19
170	S-40M170	235.0	175.0	98.0	126.0	184.0	28.93
175	S-40M175	242.0	175.0	100.0	128.0	186.0	30.20
180	S-40M180	246.0	175.0	103.0	131.0	189.0	30.28
185	S-40M185	254.0	175.0	106.0	134.0	192.0	32.54
190	S-40M190	261.0	175.0	109.0	137.0	195.0	34.04
195	S-40M195	265.0	175.0	112.0	142.0	200.0	34.80
200	S-40M200	273.0	175.0	115.0	145.0	203.0	37.49
210	S-40M210	285.0	175.0	120.0	150.0	208.0	39.91
215	S-40M215	292.0	175.0	123.0	153.0	211.0	41.94
225	S-40M225	304.0	175.0	130.0	160.0	218.0	45.71

A/F inch	MODEL NO.	D1 inch	D2 inch	T inch	C inch	OAL inch	Wt. lbs.
1.5/8	S-4026	3.386	4.567	1.102	1.811	4.094	11.30
1.3/4	S-4028	3.386	4.567	1.102	1.811	4.094	11.30
1.7/8	S-4030	3.386	4.567	1.102	1.811	4.094	11.30
2	S-4032	3.543	4.567	1.142	1.811	4.094	11.10
2.1/8	S-4034	3.642	4.882	1.181	1.811	4.094	12.90
2.1/4	S-4036	3.789	4.882	1.260	2.047	4.331	13.50
2.3/8	S-4038	3.937	5.000	1.417	2.205	4.488	14.60
2.1/2	S-4040	4.133	5.000	1.496	2.283	4.567	15.00
2.5/8	S-4042	4.281	5.000	1.496	2.283	4.567	15.20
2.3/4	S-4044	4.429	5.000	1.575	2.362	4.646	15.50
2.7/8	S-4046	4.577	5.000	1.575	2.362	4.646	15.70
2.15/16	S-4047	4.675	5.000	1.654	2.520	4.803	16.20
3	S-4048	4.774	5.000	1.732	2.520	4.803	16.40
3.1/8	S-4050	4.921	5.000	1.732	2.520	4.803	16.50
3.1/4	S-4052	4.999	5.000	1.890	2.677	4.961	16.70
3.3/8	S-4054	5.197	5.000	1.969	2.677	5.079	18.90
3.1/2	S-4056	5.354	5.000	2.047	2.756	5.118	19.50
3.5/8	S-4058	5.394	5.000	2.047	2.756	5.118	20.40
3.3/4	S-4060	5.591	5.000	2.126	2.835	5.197	20.60
3.7/8	S-4062	5.787	5.000	2.205	3.071	5.433	21.60
4	S-4064	5.827	5.000	2.205	3.071	5.433	22.40
4.1/8	S-4066	6.063	5.000	2.362	3.228	5.591	24.20
4.1/4	S-4068	6.299	5.000	2.520	3.386	5.748	25.50
4.3/8	S-4070	6.379	5.000	2.520	3.386	5.748	26.40
4.1/2	S-4072	6.496	5.000	2.638	3.504	5.866	26.80
4.5/8	S-4074	6.536	5.000	2.638	3.504	5.866	28.00
4.7/8	S-4078	7.047	5.000	2.874	3.740	6.024	30.10
5	S-4080	7.163	5.000	2.992	3.858	6.142	31.00
5.1/8	S-4082	7.203	5.000	2.992	3.858	6.142	32.10
5.1/4	S-4084	7.203	5.000	2.992	3.858	6.142	32.10
5.3/8	S-4086	7.609	5.984	3.110	4.055	6.339	41.10
5.1/2	S-4088	7.717	5.984	3.228	4.173	6.457	40.90
5.5/8	S-4090	7.757	5.984	3.228	4.173	6.457	41.70
5.3/4	S-4092	8.081	5.984	3.346	4.291	6.575	45.20
6.1/8	S-4098	9.016	6.890	3.780	4.803	7.087	59.80
6.1/2	S-40104	9.016	6.890	3.780	4.803	7.087	59.80
6.7/8	S-40110	9.528	6.890	3.937	5.039	7.323	66.40
7	S-40112	9.685	6.890	4.055	5.157	7.441	66.60
7.1/4	S-40116	10.000	6.890	4.173	5.276	7.559	71.60
7.1/2	S-40120	10.276	6.890	4.291	5.394	7.677	74.90
7.5/8	S-40122	10.433	6.890	4.409	5.591	7.874	76.60
7.3/4	S-40124	10.433	6.890	4.409	5.591	7.874	76.60
7.7/8	S-40126	10.748	6.890	4.528	5.709	7.992	82.50
8	S-40128	10.748	6.890	4.528	5.709	7.992	83.60
8.1/8	S-40130	11.220	6.890	4.724	5.906	8.189	87.80
8.1/4	S-40132	11.220	6.890	4.724	5.906	8.189	87.80
8.3/8	S-40134	11.225	6.890	4.724	5.906	8.189	88.70
8.1/2	S-40136	11.496	6.890	4.843	6.024	8.307	92.30
9	S-40144	12.029	6.890	5.118	6.299	8.583	101.80
9.1/4	S-40148	12.029	6.890	5.118	6.299	8.583	101.80

# IMPACT SOCKETS

2 1/2"



## METRIC DEEP HEXAGON



## FRACTIONAL DEEP HEXAGON



A/F mm	MODEL NO.	D1 mm	D2 mm	T mm	C mm	OAL mm	Wt. Kg.
43	S-40M43L	86.0	106.0	26.0	110.0	168.0	6.43
44	S-40M44L	86.0	106.0	26.0	110.0	168.0	6.36
45	S-40M45L	86.0	106.0	26.0	110.0	168.0	6.29
46	S-40M46L	86.0	106.0	27.0	110.0	168.0	6.22
47	S-40M47L	86.0	106.0	28.0	110.0	168.0	6.14
48	S-40M48L	86.0	116.0	28.0	110.0	168.0	7.03
49	S-40M49L	86.0	116.0	28.0	110.0	168.0	6.95
50	S-40M50L	86.0	116.0	29.0	110.0	168.0	6.86
51	S-40M51L	90.0	116.0	29.0	110.0	168.0	7.24
52	S-40M52L	90.0	116.0	29.0	110.0	168.0	7.16
54	S-40M54L	92.5	124.0	30.0	110.0	168.0	8.11
55	S-40M55L	93.8	124.0	32.0	110.0	168.0	8.18
56	S-40M56L	95.0	124.0	32.0	117.0	175.0	8.51
57	S-40M57L	96.3	124.0	32.0	117.0	175.0	8.58
58	S-40M58L	97.5	124.0	32.0	117.0	175.0	8.65
59	S-40M59L	98.8	127.0	34.0	117.0	175.0	9.04
60	S-40M60L	100.0	127.0	36.0	117.0	175.0	9.10
62	S-40M62L	103.0	127.0	36.0	127.0	185.0	9.66
65	S-40M65L	106.0	127.0	38.0	127.0	185.0	9.90
67	S-40M67L	109.0	127.0	38.0	127.0	185.0	10.13
70	S-40M70L	113.0	127.0	40.0	127.0	185.0	10.37
73	S-40M73L	116.0	127.0	40.0	127.0	185.0	10.62
75	S-40M75L	119.0	127.0	42.0	127.0	185.0	10.78
76	S-40M76L	120.0	127.0	44.0	127.0	185.0	10.85
80	S-40M80L	125.0	127.0	44.0	127.0	185.0	11.20
85	S-40M85L	129.0	127.0	48.0	137.0	195.0	12.42
86	S-40M86L	132.0	127.0	50.0	134.0	195.0	13.03
90	S-40M90L	136.0	127.0	52.0	135.0	195.0	13.40
95	S-40M95L	142.0	127.0	54.0	139.0	199.0	14.47
100	S-40M100L	148.0	127.0	56.0	135.0	195.0	15.07
105	S-40M105L	154.0	127.0	60.0	145.0	205.0	16.33
110	S-40M110L	161.0	127.0	64.0	149.0	109.0	17.67
115	S-40M115L	165.0	127.0	67.0	150.0	210.0	17.72
120	S-40M120L	173.0	127.0	70.0	150.0	210.0	19.23
125	S-40M125L	179.0	127.0	73.0	157.0	215.0	20.57
130	S-40M130L	185.0	127.0	76.0	157.0	215.0	21.44
135	S-40M135L	192.0	152.0	79.0	162.0	220.0	25.67
140	S-40M140L	196.0	152.0	82.0	167.0	225.0	26.22
145	S-40M145L	204.0	152.0	85.0	172.0	230.0	28.82
150	S-40M150L	211.0	152.0	88.0	172.0	230.0	30.38
155	S-40M155L	215.0	152.0	91.0	177.0	235.0	30.97
160	S-40M160L	223.0	152.0	94.0	177.0	235.0	33.49
165	S-40M165L	229.0	175.0	96.0	182.0	240.0	37.53
170	S-40M170L	235.0	175.0	98.0	182.0	240.0	39.22
175	S-40M175L	242.0	175.0	100.0	182.0	240.0	40.86
180	S-40M180L	246.0	175.0	103.0	187.0	245.0	41.63
185	S-40M185L	254.0	175.0	106.0	192.0	250.0	45.61
190	S-40M190L	261.0	175.0	109.0	192.0	250.0	46.93
195	S-40M195L	265.0	175.0	112.0	199.0	257.0	48.28
200	S-40M200L	273.0	175.0	115.0	202.0	260.0	51.89
210	S-40M210L	285.0	175.0	120.0	202.0	260.0	54.71
215	S-40M215L	292.0	175.0	123.0	212.0	270.0	59.42
225	S-40M225L	304.0	175.0	130.0	220.0	270.0	62.42

A/F inch	MODEL NO.	D1 inch	D2 inch	T inch	C inch	OAL inch	Wt. lbs.
1.5/8	S-4026L	3.386	4.173	1.024	4.331	6.614	13.80
1.3/4	S-4028L	3.386	4.173	1.024	4.331	6.614	13.80
1.7/8	S-4030L	3.386	4.567	1.102	4.331	6.614	13.80
2	S-4032L	3.543	4.567	1.142	4.331	6.614	15.90
2.1/8	S-4034L	3.642	4.882	1.181	4.331	6.614	17.80
2.1/4	S-4036L	3.789	4.882	1.260	4.606	6.890	18.90
2.3/8	S-4038L	3.937	5.000	1.417	4.606	6.890	20.00
2.1/2	S-4040L	4.133	5.000	1.496	5.000	7.283	21.80
2.5/8	S-4042L	4.281	5.000	1.496	5.000	7.283	22.30
2.3/4	S-4044L	4.429	5.000	1.575	5.000	7.283	22.80
2.7/8	S-4046L	4.577	5.000	1.575	5.000	7.283	23.40
2.15/16	S-4047L	4.675	5.000	1.654	5.000	7.283	23.70
3	S-4048L	4.774	5.000	1.732	5.000	7.283	24.10
3.1/8	S-4050L	4.921	5.000	1.732	5.000	7.283	24.60
3.1/4	S-4052L	4.999	5.000	1.890	5.394	7.677	26.30
3.3/8	S-4054L	5.197	5.000	1.969	5.276	7.677	28.70
3.1/2	S-4056L	5.354	5.000	2.047	5.315	7.677	29.50
3.5/8	S-4058L	5.394	5.000	2.047	5.315	7.677	30.40
3.3/4	S-4060L	5.591	5.000	2.126	5.472	7.835	31.80
3.7/8	S-4062L	5.787	5.000	2.205	5.315	7.677	32.40
4	S-4064L	5.827	5.000	2.205	5.315	7.677	33.20
4.1/8	S-4066L	6.063	5.000	2.362	5.709	8.071	35.90
4.1/4	S-4068L	6.299	5.000	2.520	5.866	8.228	38.20
4.3/8	S-4070L	6.379	5.000	2.520	5.866	8.228	39.10
4.1/2	S-4072L	6.496	5.000	2.638	5.906	8.268	39.00
4.5/8	S-4074L	6.536	5.000	2.638	5.906	8.268	40.20
4.7/8	S-4078L	7.047	5.000	2.874	6.181	8.465	45.30
5	S-4080L	7.163	5.000	2.992	6.181	8.465	47.20
5.1/8	S-4082L	7.203	5.000	2.992	6.181	8.465	48.30
5.1/4	S-4084L	7.203	5.000	2.992	6.181	8.465	48.30
5.3/8	S-4086L	7.609	5.984	3.110	6.378	8.661	57.20
5.1/2	S-4088L	7.717	5.984	3.228	6.575	8.858	57.70
5.5/8	S-4090L	7.757	5.984	3.228	6.575	8.858	58.50
5.3/4	S-4092L	8.081	5.984	3.346	6.772	9.055	64.10
6.1/8	S-4098L	9.016	6.890	3.780	7.165	9.449	82.60
6.1/2	S-40104L	9.016	6.890	3.780	7.165	9.449	82.60
6.7/8	S-40110L	9.528	6.890	3.397	7.165	9.449	89.90
7	S-40112L	9.685	6.890	4.055	7.362	9.646	91.60
7.1/4	S-40116L	10.000	6.890	4.173	7.559	9.843	100.30
7.1/2	S-40120L	10.276	6.890	4.291	7.559	9.843	103.20
7.5/8	S-40122L	10.433	6.890	4.409	7.835	10.118	106.20
7.3/4	S-40124L	10.433	6.890	4.409	7.835	10.118	106.20
7.7/8	S-40126L	10.748	6.890	4.528	7.953	10.236	114.20
8	S-40128L	10.798	6.890	4.528	7.953	10.236	115.30
8.1/8	S-40130L	11.220	6.890	4.724	7.953	10.236	120.40
8.1/4	S-40132L	11.220	6.890	4.724	7.953	10.236	120.40
8.3/8	S-40134L	11.225	6.890	4.724	7.953	10.236	121.30
8.1/2	S-40136L	11.496	6.890	4.843	8.346	10.630	130.70
9	S-40144L	12.029	6.890	5.118	8.661	10.630	138.50
9.1/4	S-40148L	12.029	6.890	5.118	8.661	10.630	138.50



2 1/2"

**IMPACT ACCESSORIES**

**DOUBLE MALE EXTENSIONS**

OAL mmc (inch)	MODEL NO.	SHANK DIA mm (inch)	HEAD DIA mm (inch)
125 (5")	S4005	85.0 (3.346)	63.5 (2.500)
150 (6")	S4006		
200 (8")	S4008		
250 (10")	S4010	85.0 (3.346)	63.5 (2.500)
380 (15")	S4015		
510 (20")	S4020		



**SQUARE ADAPTORS**

SIZE	MODEL NO.	HEAD DIA mm (inch)	OAL mm (inch)
2.1/2" F X 1.1/2" M	A4024	127.0 (5.000)	140.0 (5.511)
2.1/2" F X 3.1/2" M	A4056		185.0 (7.283)



**DOUBLE FEMALE ADAPTORS**

SIZE	MODEL NO.	HEAD DIA mm (inch)	OAL mm (inch)
2.1/2" F X 1.1/2" F	AN4024	127.0 (5.000)	115.0 (4.527)
2.1/2" F X 2.1/2" F	AN4040		120.0 (4.724)
2.1/2" F X 3.1/2" F	AN4056		162.0 (6.377)



**UNIVERSAL JOINT**

SQUARE DRIVE	MODEL NO.	DIA mm (inch)	OAL mm (inch)
2.1/2"	U4040	127.0 (5.000)	232.0 (9.133)



POWERMASTER AMERICA Impact Socket used along with a POWERMASTER AMERICA Torque Multiplier

# IMPACT SOCKETS

3 1/2"

## METRIC HEXAGON



A/F mm	MODEL NO.	D1 mm	D2 mm	T mm	C mm	OAL mm
120	S-56M120	180.0	175.0	72.0	102.0	182.0
130	S-56M130	193.0	175.0	80.0	110.0	190.0
135	S-56M135	197.0	175.0	83.0	118.0	198.0
145	S-56M145	213.0	175.0	86.0	134.0	214.0
150	S-56M150	218.0	175.0	90.0	134.0	214.0
155	S-56M155	225.0	175.0	92.0	134.0	214.0
165	S-56M165	237.0	175.0	98.0	151.0	231.0
170	S-56M170	243.0	175.0	100.0	151.0	231.0
175	S-56M175	249.0	175.0	102.0	151.0	231.0
180	S-56M180	255.0	175.0	108.0	157.0	237.0
195	S-56M195	275.0	175.0	118.0	165.0	245.0
200	S-56M200	280.0	175.0	120.0	170.0	250.0
215	S-56M215	298.0	175.0	125.0	183.0	263.0
230	S-56M230	317.0	175.0	132.0	199.0	279.0
235	S-56M235	325.0	175.0	136.0	199.0	279.0

## FRACTIONAL HEXAGON



A/F inch	MODEL NO.	D1 inch	D2 inch	T inch	C inch	OAL inch
4.5/8	S-5674	6.889	6.889	2.834	4.015	7.165
4.7/8	S-5678	7.283	6.889	2.834	4.330	7.480
5.1/4	S-5684	7.755	6.889	3.149	4.645	7.795
5.3/8	S-5686	7.874	6.889	3.267	4.645	7.795
5.5/8	S-5690	8.267	6.889	3.385	5.275	8.425
5.3/4	S-5692	8.385	6.889	3.385	5.275	8.425
6	S-5696	8.700	6.889	3.543	5.275	8.425
6.1/8	S-5698	8.858	6.889	3.622	5.275	8.425
6.1/2	S-56104	9.330	6.889	3.858	5.944	9.094
6.7/8	S-56110	9.803	6.889	4.015	5.944	9.094
7.1/4	S-56116	10.275	6.889	4.409	6.181	9.330
7.5/8	S-56122	10.826	6.889	4.645	6.496	9.645
8	S-56128	11.220	6.889	4.724	7.204	10.354
8.3/8	S-56134	11.653	6.889	4.803	7.204	10.354
9.1/8	S-56146	12.598	6.889	5.196	7.834	10.984

## METRIC DEEP HEXAGON



A/F mm	MODEL NO.	D1 mm	D2 mm	T mm	C mm	OAL mm
120	S-56M120L	180.0	175.0	72.0	197.0	277.0
130	S-56M130L	193.0	175.0	80.0	200.0	280.0
135	S-56M135L	197.0	175.0	83.0	200.0	280.0
145	S-56M145L	213.0	175.0	86.0	215.0	295.0
150	S-56M150L	218.0	175.0	90.0	215.0	295.0
155	S-56M155L	225.0	175.0	92.0	217.0	297.0
165	S-56M165L	237.0	175.0	98.0	233.0	313.0
170	S-56M170L	243.0	175.0	100.0	233.0	313.0
175	S-56M175L	249.0	175.0	102.0	233.0	313.0
180	S-56M180L	255.0	175.0	108.0	240.0	320.0
195	S-56M195L	275.0	175.0	118.0	248.0	328.0
200	S-56M200L	280.0	175.0	120.0	252.0	332.0
215	S-56M215L	298.0	175.0	125.0	266.0	346.0
230	S-56M230L	317.0	175.0	132.0	279.0	359.0
235	S-56M235L	325.0	175.0	136.0	282.0	362.0

## FRACTIONAL DEEP HEXAGON



A/F inch	MODEL NO.	D1 inch	D2 inch	T inch	C inch	OAL inch
4.5/8	S-5674L	6.889	6.889	2.834	7.756	10.906
4.7/8	S-5678L	7.283	6.889	2.834	7.756	10.906
5.1/4	S-5684L	7.755	6.889	3.149	7.874	11.024
5.3/8	S-5686L	7.874	6.889	3.267	7.874	11.024
5.5/8	S-5690L	8.267	6.889	3.385	8.543	11.693
5.3/4	S-5692L	8.385	6.889	3.385	8.543	11.693
6	S-5696L	8.700	6.889	3.543	8.543	11.693
6.1/8	S-5698L	9.055	6.889	3.622	8.543	11.693
6.1/2	S-56104L	9.330	6.889	3.858	9.173	12.323
6.7/8	S-56110L	9.803	6.889	4.015	9.173	12.323
7.1/4	S-56116L	10.275	6.889	4.409	9.448	12.598
7.5/8	S-56122L	10.826	6.889	4.645	9.763	12.913
8	S-56128L	11.220	6.889	4.724	10.472	13.322
8.3/8	S-56134L	11.653	6.889	4.803	10.472	13.622
9.1/8	S-56146L	12.598	6.889	5.196	11.102	14.252

# IMPACT ACCESSORIES

## DOUBLE MALE EXTENSIONS

OAL mm (inch)	MODEL NO.	SHANK DIA mm (inch)	HEAD DIA mm (inch)
250 (10")	S5610	120.0 (4.724)	175.0 (6.889)
510 (20")	S5620		



## SQUARE ADAPTORS

SIZE	MODEL NO.	HEAD DIA mm (inch)	OAL mm (inch)
3.1/2" F X 2.1/2" M	A5640	175.0 (6.889)	185.0 (7.283)



## DOUBLE FEMALE ADAPTORS

SIZE	MODEL NO.	HEAD DIA mm (inch)	OAL mm (inch)
3.1/2" F X 2.1/2" F	AN5640	175.0 (6.889)	165.0 (6.496)





# IMPACT SOCKETS

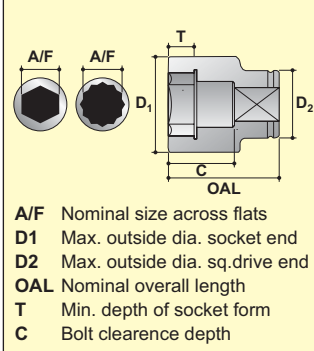

## METRIC # 5 SPLINE



A/F mm	MODEL NO.	D1 mm	D2 mm	T mm	C mm	OAL mm
19	S-95M19	48.0	56.0	16.0	35.0	68.0
20	S-95M20	48.0	56.0	16.0	35.0	68.0
21	S-95M21	48.0	56.0	16.0	35.0	68.0
22	S-95M22	48.0	56.0	16.0	35.0	68.0
23	S-95M23	48.0	56.0	16.0	35.0	68.0
24	S-95M24	48.0	56.0	16.0	35.0	68.0
25	S-95M25	50.0	56.0	18.0	37.0	70.0
26	S-95M26	50.0	56.0	18.0	37.0	70.0
27	S-95M27	52.0	56.0	20.0	39.0	72.0
28	S-95M28	52.0	56.0	20.0	39.0	72.0
29	S-95M29	53.0	56.0	22.0	41.0	74.0
30	S-95M30	53.5	56.0	22.0	41.0	74.0
31	S-95M31	54.0	56.0	22.0	41.0	74.0
32	S-95M32	54.0	56.0	22.0	41.0	74.0
33	S-95M33	58.0	56.0	22.0	41.0	74.0
34	S-95M34	58.0	56.0	22.0	41.0	74.0
35	S-95M35	59.8	56.0	25.0	44.0	77.0
36	S-95M36	64.0	56.0	25.0	44.0	77.0
37	S-95M37	63.0	56.0	25.0	44.0	77.0
38	S-95M38	63.5	56.0	25.0	44.0	77.0
39	S-95M39	64.0	56.0	25.0	44.0	77.0
40	S-95M40	64.0	56.0	25.0	44.0	77.0
41	S-95M41	68.0	56.0	28.0	47.0	80.0
42	S-95M42	68.0	56.0	28.0	47.0	80.0
43	S-95M43	68.0	56.0	28.0	47.0	80.0
44	S-95M44	73.0	56.0	28.0	49.0	82.0
45	S-95M45	73.0	56.0	28.0	49.0	82.0
46	S-95M46	73.0	56.0	28.0	49.0	82.0
47	S-95M47	73.0	56.0	28.0	49.0	82.0
48	S-95M48	77.0	56.0	28.0	49.0	82.0
49	S-95M49	77.3	56.0	28.0	51.0	84.0
50	S-95M50	78.0	56.0	28.0	51.0	84.0
51	S-95M51	78.0	56.0	30.0	53.0	86.0
52	S-95M52	82.0	56.0	30.0	53.0	86.0
54	S-95M54	82.0	56.0	30.0	53.0	86.0
55	S-95M55	86.0	56.0	34.0	59.0	92.0
56	S-95M56	86.0	56.0	34.0	59.0	92.0
57	S-95M57	88.0	86.0	34.0	59.0	92.0
58	S-95M58	88.0	86.0	34.0	59.0	92.0
59	S-95M59	88.0	86.0	34.0	59.0	92.0
60	S-95M60	88.0	86.0	36.0	61.0	94.0
61	S-95M61	92.3	86.0	36.0	61.0	94.0
62	S-95M62	93.5	86.0	34.0	59.0	92.0
65	S-95M65	97.3	86.0	38.0	63.0	96.0
67	S-95M67	99.8	86.0	38.0	63.0	96.0
70	S-95M70	104.0	86.0	40.0	65.0	98.0
73	S-95M73	107.0	86.0	40.0	67.0	100.0
75	S-95M75	107.0	86.0	42.0	69.0	102.0
76	S-95M76	111.0	86.0	42.0	69.0	102.0
80	S-95M80	116.0	86.0	42.0	69.0	102.0

## FRACTIONAL # 5 SPLINE



A/F inch	MODEL NO.	D1 inch	D2 inch	T inch	C inch	OAL inch
3/4	S-9512	2.200	0.911	0.629	1.375	2.672
13/16	S-9513	2.200	0.979	0.629	1.375	2.672
7/8	S-9514	2.200	1.051	0.629	1.375	2.672
15/16	S-9515	2.200	1.123	0.629	1.375	2.672
1	S-9516	2.200	1.196	0.707	1.454	2.750
1.1/16	S-9517	2.200	1.268	0.707	1.454	2.750
1.1/8	S-9518	2.200	1.340	0.786	1.532	2.289
1.3/16	S-9519	2.200	1.413	0.864	1.611	2.908
1.1/4	S-9520	2.200	1.485	0.864	1.611	2.908
1.5/16	S-9521	2.200	1.557	0.864	1.611	2.908
1.3/8	S-9522	2.200	1.625	0.982	1.729	3.026
1.7/16	S-9523	2.200	1.697	0.982	1.729	3.026
1.1/2	S-9524	2.200	1.770	0.982	1.729	3.026
1.9/16	S-9525	2.200	1.842	0.982	1.729	3.026
1.5/8	S-9526	2.200	1.914	1.100	1.847	3.143
1.11/16	S-9527	2.200	1.986	1.100	1.847	3.143
1.3/4	S-9528	2.200	2.059	1.100	1.925	3.222
1.13/16	S-9529	2.200	2.131	1.100	1.925	3.222
1.7/8	S-9530	2.200	2.199	1.100	1.925	3.222
1.15/16	S-9531	2.200	2.276	1.100	2.004	3.301
2	S-9532	2.200	2.352	1.179	2.083	3.379
2.1/16	S-9533	2.200	2.420	1.179	2.083	3.379
2.1/8	S-9534	2.200	2.506	1.179	2.083	3.379
2.3/16	S-9535	2.200	2.560	1.336	2.318	3.615
2.1/4	S-9536	3.379	2.633	1.336	2.318	3.615
2.5/16	S-9537	3.379	2.705	1.336	2.318	3.615
2.3/8	S-9538	3.379	2.777	1.415	2.397	3.694
2.7/16	S-9539	3.379	2.850	1.415	2.397	3.694
2.1/2	S-9540	3.379	2.922	1.493	2.475	3.772
2.9/16	S-9541	3.379	2.994	1.493	2.475	3.772
2.5/8	S-9542	3.379	3.066	1.493	2.475	3.772
2.11/16	S-9543	3.379	3.134	1.572	2.554	3.851
2.3/4	S-9544	3.379	3.211	1.572	2.554	3.851
2.13/16	S-9545	3.379	3.279	1.572	2.554	3.851
2.7/8	S-9546	3.379	3.356	1.572	2.663	3.929
2.15/16	S-9547	3.379	3.423	1.650	2.711	4.008
3	S-9548	3.379	3.496	1.650	2.711	4.008
3.1/16	S-9549	3.379	3.572	1.650	2.711	4.008
3.1/8	S-9550	3.379	3.640	1.650	2.711	4.008
3.1/4	S-9552	3.379	3.785	1.729	2.947	4.244
3.5/16	S-9553	4.912	3.862	1.807	3.026	4.322
3.3/8	S-9554	5.039	3.385	1.850	3.149	4.921
3.1/2	S-9556	5.118	3.385	1.850	3.149	4.921
3.5/8	S-9558	5.275	3.385	1.968	3.149	4.921
3.3/4	S-9560	5.354	3.385	2.125	3.149	4.921
3.7/8	S-9562	5.433	3.385	2.125	3.149	4.921
4	S-9564	5.511	3.385	2.125	3.149	4.921

# IMPACT SOCKETS



## METRIC DEEP # 5 SPLINE



A/F mm	MODEL NO.	D1 mm	D2 mm	T mm	C mm	OAL mm
21	S-95M21L	48.0	56.0	14.0	115.0	160.0
22	S-95M22L	48.0	56.0	14.0	115.0	160.0
23	S-95M23L	48.0	56.0	14.0	115.0	160.0
24	S-95M24L	50.0	56.0	16.0	115.0	160.0
25	S-95M25L	50.0	56.0	16.0	115.0	160.0
26	S-95M26L	52.0	56.0	16.0	115.0	160.0
27	S-95M27L	52.0	56.0	16.0	115.0	160.0
28	S-95M28L	52.0	56.0	16.0	115.0	160.0
29	S-95M29L	54.0	56.0	16.0	115.0	160.0
30	S-95M30L	54.0	56.0	21.0	115.0	160.0
31	S-95M31L	60.0	56.0	21.0	115.0	160.0
32	S-95M32L	60.0	56.0	21.0	115.0	160.0
33	S-95M33L	60.0	56.0	21.0	115.0	160.0
34	S-95M34L	60.0	56.0	21.0	115.0	160.0
35	S-95M35L	60.0	56.0	21.0	115.0	160.0
36	S-95M36L	63.0	56.0	25.0	115.0	160.0
37	S-95M37L	63.0	56.0	25.0	115.0	160.0
38	S-95M38L	63.0	56.0	25.0	115.0	160.0
39	S-95M39L	67.0	56.0	25.0	115.0	160.0
40	S-95M40L	67.0	56.0	25.0	115.0	160.0
41	S-95M41L	67.0	56.0	28.0	115.0	160.0
42	S-95M42L	67.0	56.0	28.0	115.0	160.0
43	S-95M43L	67.0	56.0	28.0	115.0	160.0
44	S-95M44L	73.0	56.0	28.0	115.0	160.0
45	S-95M45L	73.0	56.0	28.0	115.0	160.0
46	S-95M46L	73.0	56.0	28.0	115.0	160.0
47	S-95M47L	73.0	56.0	28.0	115.0	160.0
48	S-95M48L	73.0	56.0	28.0	115.0	160.0
49	S-95M49L	73.0	56.0	28.0	115.0	160.0
50	S-95M50L	82.0	56.0	28.0	115.0	160.0
51	S-95M51L	82.0	56.0	28.0	115.0	160.0
52	S-95M52L	82.0	56.0	28.0	115.0	160.0

## FRACTIONAL DEEP # 5 SPLINE



A/F inch	MODEL NO.	D1 inch	D2 inch	T inch	C inch	OAL inch
3/4	S-9512L	1.889	2.362	0.551	4.527	6.299
13/16	S-9513L	1.889	2.362	0.551	4.527	6.299
7/8	S-9514L	1.889	2.362	0.551	4.527	6.299
15/16	S-9515L	1.968	2.362	0.629	4.527	6.299
1	S-9516L	1.968	2.362	0.629	4.527	6.299
1.1/16	S-9517L	2.047	2.362	0.629	4.527	6.299
1.1/8	S-9518L	2.047	2.362	0.629	4.527	6.299
1.3/16	S-9519L	2.125	2.362	0.826	4.527	6.299
1.1/4	S-9520L	2.362	2.362	0.826	4.527	6.299
1.5/16	S-9521L	2.362	2.362	0.826	4.527	6.299
1.3/8	S-9522L	2.362	2.362	0.826	4.527	6.299
1.7/16	S-9523L	2.480	2.362	0.984	4.527	6.299
1.1/2	S-9524L	2.480	2.362	0.984	4.527	6.299
1.9/16	S-9525L	2.637	2.362	0.984	4.527	6.299
1.5/8	S-9526L	2.637	2.362	1.102	4.527	6.299
1.11/16	S-9527L	2.637	2.362	1.102	4.527	6.299
1.3/4	S-9528L	2.874	2.362	1.102	4.527	6.299
1.13/16	S-9529L	2.874	2.362	1.102	4.527	6.299
1.7/8	S-9530L	2.874	2.362	1.102	4.527	6.299
1.15/16	S-9531L	2.874	2.362	1.102	4.527	6.299
2	S-9532L	3.228	2.362	1.102	4.527	6.299
2.1/16	S-9533L	3.228	2.362	1.102	4.527	6.299
2.1/8	S-9534L	3.228	2.362	1.102	4.527	6.299
2.3/16	S-9535L	3.228	2.362	1.181	4.527	6.299
2.1/4	S-9536L	3.464	3.385	1.181	4.527	6.299
2.5/16	S-9537L	3.464	3.385	1.181	4.527	6.299
2.3/8	S-9538L	3.464	3.385	1.259	4.527	6.299
2.7/16	S-9539L	3.464	3.385	1.259	4.527	6.299
2.1/2	S-9540L	3.937	3.385	1.259	4.527	6.299
2.9/16	S-9541L	3.937	3.385	1.496	4.527	6.299
2.5/8	S-9542L	3.937	3.385	1.496	4.527	6.299
2.11/16	S-9543L	3.937	3.385	1.496	4.527	6.299

# IMPACT ACCESSORIES

## REGULAR EXTENSIONS

OAL mm (inch)	MODEL NO.	SHANK DIA mm (inch)	HEAD DIA mm (inch)
200 (8") 381 (15")	E9508 E9515	42.0 (1.653)	60.0 (2.362)



## SQUARE ADAPTORS

SIZE	MODEL NO.	HEAD DIA mm (inch)	OAL mm (inch)
# 5 F X 1" M # 5 F X 1.1/2" M	A9516 A9524	60.0 (2.362)	90.0 (3.543) 100.0 (3.937)



## UNIVERSAL JOINT

SPLINE DRIVE	MODEL NO.	DIA mm (inch)	OAL mm (inch)
# 5	# 5 SPLINE	60.0 (2.362)	152.0 (6.000)



**SOCKET ACCESSORIES**

**REVERSIBLE RATCHETS**

SQUARE DRIVE	MODEL NO.	APP. OAL	Wt. Kg.
3/8	PRH38	220	0.58
1/2	PRH50	290	0.65
3/4	PRH75	500	2.80
1	PRH100	610	4.30



**RATCHET ADAPTORS**

SQUARE DRIVE	MODEL NO.	APP. OAL	Wt. Kg.
1/2	PRA50	75	0.20
3/4	PRA75	100	0.45
1	PRA100	117	0.95



**INDUSTRIAL T-HANDLE**

SQUARE DRIVE	MODEL NO.	APP. OAL	Wt. Kg.
3/8	PTH38	250	0.35
1/2	PTH50	300	0.62
3/4	PTH75	500	2.40
1	PTH100	750	4.95
1.1/2	PTH150	920	15.80



**SWIVEL HANDLE**

SQUARE DRIVE	MODEL NO.	APP. OAL	Wt. Kg.
3/8	PSH38	270	0.30
1/2	PSH50	380	0.60
3/4	PSH75	530	2.60
1	PSH100	800	4.55



**BALL TYPE UNIVERSAL JOINT**

SQUARE DRIVE	MODEL NO.	DIA	APP. OAL	Wt. Kg.
1/2	UJ08B	30	68	0.25
3/4	UJ12B	44	85	0.55
1	UJ16B	62	110	1.15



**SQUARE COUPLERS**

SQUARE DRIVE	MODEL NO.	APP. OAL	Wt. Kg.
3/8	PSC38	35	0.02
1/2	PSC50	45	0.05
3/4	PSC75	50	0.13
1	PSC100	80	0.40





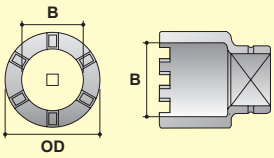

OD Max. outside dia. socket end  
 W/O S Without skirt  
 S Skirted  
 B Bore dia.

# CASTELLATED SOCKETS



## FRACTIONAL 1" SQ. DRIVE

NOMINAL SIZE	MODEL NO.	OD inch	OAL (W/O S) inch	OAL (S) inch	B inch
1.1/4	CS1620	2.1/4	2	3.1/2	1.1/8
1.3/8	CS1622	2.3/4	2	3.3/4	1.1/4
1.1/2	CS1624	2.3/4	2	4	1.3/8
1.3/4	CS1628	3	2.1/8	4.1/8	1.5/8
2	CS1632	3.1/8	2.1/8	4.1/8	1.7/8
2.1/4	CS1636	3.1/2	2.1/4	4.3/4	2.1/8
2.1/2	CS1640	3.7/8	2.1/4	4.3/4	2.3/8
2.3/4	CS1644	4.1/4	2.1/2	5.3/8	2.5/8
3	CS1648	4.5/8	2.1/2	5.3/8	2.7/8
3.1/2	CS1656	5.3/8	2.3/4	6.3/8	3.3/8
4	CS1664	6.1/8	2.3/4	6.7/8	3.7/8
4.1/2	CS1672	6.7/8	3	7.5/8	4.3/8

## FRACTIONAL 1.1/2" SQ. DRIVE

NOMINAL SIZE	MODEL NO.	OD inch	OAL (W/O S) inch	OAL (S) inch	B inch
2.1/4	CS2436	3.1/2	2.3/8	4.1/8	2.1/8
2.1/2	CS2440	3.7/8	2.3/8	4.1/8	2.3/8
2.3/4	CS2444	4.1/4	2.5/8	5.1/2	2.5/8
3	CS2448	4.5/8	2.5/8	5.1/2	2.7/8
3.1/2	CS2456	5.3/8	2.7/8	6.1/2	3.3/8
4	CS2464	6.1/8	2.7/8	7	3.7/8
4.1/2	CS2472	6.7/8	3.1/8	7.3/4	4.3/8
5	CS2480	7.5/8	3.1/8	7.7/8	4.7/8
5.1/2	CS2488	8.3/8	3.3/8	8.7/8	5.3/8
6	CS2496	9.1/4	3.3/8	9.3/8	5.7/8
6.1/2	CS24104	10	3.1/2	9.1/2	6.3/8
7	CS24112	10.5/8	3.1/2	10.3/8	6.7/8

## FRACTIONAL 2.1/2" SQ. DRIVE

NOMINAL inch	MODEL NO.	OD inch	OAL (W/O S) inch	OAL (S) inch	B inch
2.3/4	CS40044	4.1/4	3.1/4	6.1/8	2.5/8
3	CS40048	4.5/8	3.1/4	6.1/8	2.7/8
3.1/2	CS40056	5.3/8	3.1/2	7.1/8	3.3/8
4	CS40064	6.1/8	3.1/2	7.5/8	3.7/8
4.1/2	CS40072	6.7/8	3.3/4	8.3/8	4.3/8
5	CS40080	7.5/8	3.3/4	8.1/2	4.7/8
5.1/2	CS40088	8.3/8	4	9.1/2	5.3/8
6	CS40096	9.1/4	4	10	5.7/8
6.1/2	CS40104	10	4.1/8	10.1/2	6.3/8
7	CS40112	10.5/8	4.1/8	11	6.7/8

## FRACTIONAL 3.1/2" SQ. DRIVE

NOMINAL inch	MODEL NO.	OD inch	OAL (W/O S) inch	OAL (S) inch	B inch
4.1/2	CS56072	6.7/8	5	9.5/8	4.3/8
5	CS56080	7.5/8	5	9.3/4	4.7/8
5.1/2	CS56088	8.3/8	5.1/4	10.3/4	5.3/8
6	CS56096	9.1/4	5.1/4	11	5.7/8
6.1/2	CS26104	10	5.5/8	11.1/2	6.3/8
7	CS56112	10.5/8	5.5/8	12	6.7/8

**Note:** Skirted Sockets with long clearance for stud can be made to specific length against order.

## SLUGGING WRENCHES

*'POWERMASTER AMERICA' SLUGGING WRENCHES*

1. Drop forged from high tensile alloy.
2. Machined to closed tolerances to ISO specifications.
3. Heat treated to achieve optimum Impact resistance.
4. Electroplating followed by black oxidizing to prevent from rusting.
5. Larger striking area to increase safety in use.
6. Greater sectional area for longer life.
7. Hexagon opening depth to ensure positive seating on nuts / bolts.
8. Chamfered openings for ease of location on nuts / bolts.
9. Greater offset height allows clear hammering in offset Slugging Wrenches.
10. Clear marking of size and model.

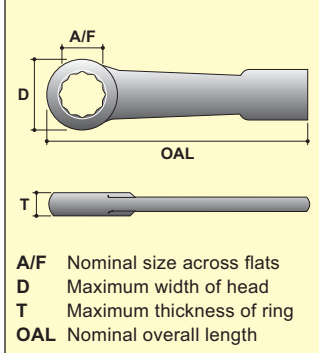

**STRAIGHT SLUGGING WRENCHES**



**METRIC BIHEXAGON**



A / F mm	MODEL NO.	T mm	D mm	OAL mm	Wt. Kg.
22	MSW22	18.0	48.0	182.0	0.610
23	MSW23	18.0	48.0	182.0	0.610
24	MSW24	18.0	48.0	182.0	0.610
25	MSW25	18.0	48.0	182.0	0.590
26	MSW26	18.0	48.0	182.0	0.590
27	MSW27	18.0	48.0	182.0	0.590
28	MSW28	18.0	54.0	185.0	0.580
29	MSW29	18.0	54.0	185.0	0.560
30	MSW30	18.0	54.0	185.0	0.550
31	MSW31	18.0	54.0	185.0	0.540
32	MSW32	18.0	54.0	185.0	0.550
33	MSW33	18.0	54.0	185.0	0.540
34	MSW34	18.0	54.0	185.0	0.540
35	MSW35	18.0	54.0	185.0	0.540
36	MSW36	22.0	64.0	215.0	1.060
37	MSW37	22.0	64.0	215.0	1.060
38	MSW38	22.0	64.0	215.0	1.040
39	MSW39	22.0	64.0	215.0	1.030
40	MSW40	22.0	64.0	215.0	1.030
41	MSW41	22.0	64.0	215.0	1.030
42	MSW42	22.0	64.0	215.0	1.020
43	MSW43	25.0	76.0	238.0	1.480
44	MSW44	25.0	76.0	238.0	1.470
45	MSW45	25.0	76.0	238.0	1.430
46	MSW46	25.0	84.0	242.0	1.400
47	MSW47	25.0	84.0	242.0	1.380
48	MSW48	25.0	84.0	242.0	1.360
49	MSW49	25.0	84.0	242.0	1.350
50	MSW50	25.0	84.0	242.0	1.340
51	MSW51	25.0	84.0	242.0	1.400
52	MSW52	25.0	84.0	242.0	1.400
54	MSW54	25.0	84.0	242.0	2.350
55	MSW55	28.0	88.0	262.0	2.320
56	MSW56	28.0	88.0	262.0	2.325
57	MSW57	28.0	88.0	262.0	2.310
58	MSW58	28.0	88.0	262.0	2.300
59	MSW59	28.0	94.0	265.0	2.250
60	MSW60	28.0	94.0	265.0	2.140
61	MSW61	28.0	94.0	265.0	2.140
62	MSW62	28.0	94.0	265.0	2.500
65	MSW65	30.0	104.0	285.0	2.710
67	MSW67	30.0	104.0	285.0	2.770
70	MSW70	35.0	110.0	315.0	3.410
73	MSW73	35.0	110.0	315.0	3.410
75	MSW75	35.0	110.0	315.0	3.400

**METRIC BIHEXAGON (cont.)**



A / F mm	MODEL NO.	T mm	D mm	OAL mm	Wt. Kg.
76	MSW76	35.0	110.0	315.0	3.370
80	MSW80	38.0	126.0	340.0	4.860
85	MSW85	38.0	126.0	340.0	4.400
86	MSW86	38.0	126.0	340.0	4.300
90	MSW90	42.0	152.0	400.0	4.650
95	MSW95	42.0	152.0	400.0	4.360
100	MSW100	42.0	152.0	400.0	7.490
105	MSW105	50.0	172.0	410.0	10.580
110	MSW110	50.0	172.0	435.0	11.670
115	MSW115	50.0	172.0	435.0	10.760
120	MSW120	56.0	194.0	475.0	16.070
125	MSW125	56.0	194.0	475.0	16.960
130	MSW130	60.0	205.0	505.0	16.850
135	MSW135	60.0	205.0	510.0	16.550
140	MSW140	65.0	230.0	565.0	19.000
145	MSW145	65.0	230.0	565.0	18.810
150	MSW150	65.0	230.0	565.0	18.550
155	MSW155	65.0	230.0	565.0	18.350
160	MSW160	70.0	270.0	635.0	29.900
165	MSW165	70.0	270.0	635.0	29.700
170	MSW170	70.0	270.0	635.0	29.250
175	MSW175	70.0	270.0	635.0	28.850
180	MSW180	70.0	270.0	635.0	28.500
185	MSW185	75.0	295.0	680.0	35.600
190	MSW190	75.0	295.0	680.0	35.400
195	MSW195	75.0	295.0	680.0	35.200
200	MSW200	75.0	295.0	680.0	34.900
205	MSW205	75.0	295.0	680.0	34.700
210	MSW210	80.0	325.0	725.0	50.850
215	MSW215	80.0	325.0	725.0	50.550
220	MSW220	80.0	325.0	725.0	50.100
225	MSW225	80.0	325.0	725.0	49.800
230	MSW230	80.0	325.0	725.0	49.500



Table continued next column

STRAIGHT SLUGGING WRENCHES



FRACTIONAL BIHEXAGON



FRACTIONAL BIHEXAGON (cont.)



A / F inch	MODEL NO.	T inch	D inch	OAL inch	Wt. lbs.
7/8	ASW14	0.708	1.889	7.165	1.390
15/16	ASW15	0.708	1.889	7.165	1.340
1	ASW16	0.708	1.889	7.165	1.320
1.1/16	ASW17	0.708	1.889	7.165	1.300
1.1/8	ASW18	0.708	2.125	7.283	1.365
1.3/16	ASW19	0.708	2.125	7.283	1.200
1.1/4	ASW20	0.708	2.125	7.283	1.500
1.5/16	ASW21	0.708	2.125	7.283	1.200
1.3/8	ASW22	0.708	2.125	7.283	1.200
1.7/16	ASW23	0.866	2.519	8.464	2.300
1.1/2	ASW24	0.866	2.519	8.464	2.400
1.9/16	ASW25	0.866	2.519	8.464	2.350
1.5/8	ASW26	0.866	2.519	8.464	2.300
1.11/16	ASW27	0.984	2.992	9.370	3.080
1.3/4	ASW28	0.984	2.992	9.370	3.080
1.13/16	ASW29	0.984	2.992	9.370	3.080
1.7/8	ASW30	0.984	2.992	9.370	3.230
1.15/16	ASW31	0.984	3.149	9.448	3.230
2	ASW32	0.984	3.149	9.448	3.080
2.1/16	ASW33	0.984	3.149	9.448	2.930
2.1/8	ASW34	0.984	3.149	9.448	3.020
2.3/16	ASW35	1.102	3.464	10.314	4.840
2.1/4	ASW36	1.102	3.464	10.314	4.970
2.5/16	ASW37	1.102	3.700	10.433	4.990
2.3/8	ASW38	1.102	3.700	10.433	5.040
2.7/16	ASW39	1.102	3.700	10.433	4.700
2.1/2	ASW40	1.102	3.700	10.433	3.080
2.9/16	ASW41	1.181	4.094	11.220	5.875
2.5/8	ASW42	1.181	4.094	11.220	7.500
2.11/16	ASW43	1.181	4.094	11.220	7.500
2.3/4	ASW44	1.377	4.330	12.401	7.500
2.13/16	ASW45	1.377	4.330	12.401	7.180
2.7/8	ASW46	1.377	4.330	12.401	7.195
2.15/16	ASW47	1.377	4.330	12.401	7.200
3	ASW48	1.377	4.330	12.401	7.400
3.1/16	ASW49	1.496	4.960	13.385	9.130
3.1/8	ASW50	1.496	4.960	13.385	8.910
3.3/16	ASW51	1.496	4.960	13.385	9.130
3.1/4	ASW52	1.496	4.960	13.385	9.350
3.5/16	ASW53	1.496	4.960	13.385	9.570
3.3/8	ASW54	1.496	4.960	13.385	9.680
3.7/16	ASW55	1.653	5.984	15.748	9.460
3.1/2	ASW56	1.653	5.984	15.748	9.460
3.9/16	ASW57	1.653	5.984	15.748	9.500
3.5/8	ASW58	1.653	5.984	15.748	9.480
3.11/16	ASW59	1.653	5.984	15.748	9.530
3.3/4	ASW60	1.653	5.984	15.748	9.590
3.13/16	ASW61	1.653	5.984	15.748	9.640

A / F inch	MODEL NO.	T mm	D mm	OAL mm	Wt. lbs.
3.7/8	ASW62	1.653	5.984	15.748	15.000
3.15/16	ASW63	1.653	5.984	15.748	16.480
4	ASW64	1.653	5.984	15.748	19.470
4.1/16	ASW65	1.653	5.984	15.748	19.690
4.1/8	ASW66	1.968	6.771	16.141	23.280
4.3/16	ASW67	1.968	6.771	16.141	23.100
4.1/4	ASW68	1.968	6.771	16.141	22.800
4.5/16	ASW69	1.968	6.771	17.125	24.550
4.3/8	ASW70	1.968	6.771	17.125	24.200
4.7/16	ASW71	1.968	6.771	17.125	23.980
4.1/2	ASW72	1.968	6.771	17.125	23.670
4.5/8	ASW74	2.204	7.637	18.700	29.480
4.3/4	ASW76	2.204	7.637	18.700	29.700
4.7/8	ASW78	2.204	7.637	18.700	37.310
5	ASW80	2.204	8.070	19.881	36.850
5.1/8	ASW82	2.204	8.070	19.881	36.630
5.3/16	ASW83	2.204	8.070	19.881	36.520
5.1/4	ASW84	2.204	8.070	19.881	36.520
5.3/8	ASW86	2.559	9.055	22.244	43.560
5.1/2	ASW88	2.559	9.055	22.244	41.800
5.5/8	ASW90	2.559	9.055	22.244	41.580
5.3/4	ASW92	2.559	9.055	22.244	41.560
5.7/8	ASW94	2.559	9.055	22.244	40.810
6	ASW96	2.559	9.055	22.244	40.370
6.1/8	ASW98	2.559	9.055	22.244	39.820
6.1/4	ASW100	2.755	10.629	25.000	66.550
6.3/8	ASW102	2.755	10.629	25.000	66.000
6.1/2	ASW104	2.755	10.629	25.000	65.340
6.5/8	ASW106	2.755	10.629	25.000	65.120
6.3/4	ASW108	2.755	10.629	25.000	64.240
6.7/8	ASW110	2.755	10.629	25.000	63.470
7	ASW112	2.755	10.629	25.000	63.030
7.1/8	ASW114	2.952	11.614	26.771	78.760
7.1/4	ASW116	2.952	11.614	26.771	78.320
7.3/8	ASW118	2.952	11.614	26.771	78.100
7.1/2	ASW120	2.952	11.614	26.771	78.880
7.5/8	ASW122	2.952	11.614	26.771	77.660
7.3/4	ASW124	2.952	11.614	26.771	77.440
7.13/16	ASW125	2.952	11.614	26.771	76.780
7.7/8	ASW126	2.952	11.614	26.771	76.120
8	ASW128	2.952	11.614	26.771	76.560
8.1/8	ASW130	3.149	12.795	28.543	112.420
8.1/4	ASW132	3.149	12.795	28.543	111.540
8.3/8	ASW134	3.149	12.795	28.543	110.660
8.1/2	ASW136	3.149	12.795	28.543	110.220
8.5/8	ASW138	3.149	12.795	28.543	109.780
8.7/8	ASW142	3.149	12.795	28.543	109.340
9	ASW144	3.149	12.795	28.543	108.900

Table continued next column



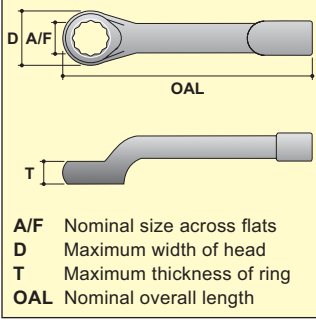

# OFFSET SLUGGING WRENCHES



## METRIC BIHEXAGON



A / F mm	MODEL NO.	T mm	D mm	OAL mm	Wt. kg.
24	MOSW24	20.0	42.0	250.0	1.000
27	MOSW27	25.0	52.0	270.0	1.060
30	MOSW30	25.0	52.0	270.0	1.150
32	MOSW32	25.0	52.0	270.0	1.290
34	MOSW34	25.0	52.0	270.0	1.640
35	MOSW35	32.0	68.0	312.0	1.550
36	MOSW36	32.0	68.0	312.0	1.500
38	MOSW38	32.0	68.0	312.0	1.750
40	MOSW40	32.0	68.0	312.0	1.950
41	MOSW41	32.0	68.0	312.0	2.150
43	MOSW43	35.0	82.0	340.0	2.850
46	MOSW46	35.0	82.0	340.0	2.630
47	MOSW47	35.0	82.0	340.0	2.610
48	MOSW48	35.0	82.0	340.0	2.600
49	MOSW49	35.0	82.0	340.0	2.450
50	MOSW50	35.0	82.0	340.0	2.350
51	MOSW51	35.0	82.0	340.0	3.190
52	MOSW52	38.0	82.0	360.0	3.000
54	MOSW54	38.0	82.0	360.0	3.000
55	MOSW55	38.0	82.0	360.0	2.930
56	MOSW56	38.0	82.0	360.0	2.980
57	MOSW57	38.0	82.0	360.0	4.850
58	MOSW58	38.0	82.0	360.0	4.750
59	MOSW59	38.0	82.0	360.0	4.900
60	MOSW60	44.0	110.0	380.0	4.430
61	MOSW61	44.0	110.0	380.0	4.350
62	MOSW62	44.0	110.0	380.0	4.300
65	MOSW65	44.0	110.0	380.0	5.650
67	MOSW67	44.0	110.0	380.0	5.500
70	MOSW70	50.0	127.0	400.0	7.320
73	MOSW73	50.0	127.0	400.0	7.000
75	MOSW75	50.0	127.0	400.0	6.880
76	MOSW76	50.0	127.0	400.0	6.750
80	MOSW80	50.0	127.0	400.0	8.630
85	MOSW85	50.0	127.0	400.0	7.480
86	MOSW86	57.0	152.0	465.0	9.100
90	MOSW90	57.0	152.0	465.0	8.970
95	MOSW95	57.0	152.0	465.0	11.680
100	MOSW100	57.0	152.0	465.0	11.470
105	MOSW105	63.5	194.0	540.0	12.000
110	MOSW110	63.5	194.0	540.0	11.740
115	MOSW115	63.5	194.0	540.0	11.710
120	MOSW120	63.5	194.0	540.0	11.550
125	MOSW125	63.5	194.0	540.0	11.250
130	MOSW130	63.5	194.0	540.0	11.050

## FRACTIONAL BIHEXAGON



A / F inch	MODEL NO.	T inch	D inch	OAL inch	Wt. lbs.
15/16	AOSW15	0.787	1.653	9.842	2.160
1	AOSW16	0.787	1.653	9.842	2.200
1.1/16	AOSW17	0.984	2.047	10.629	2.330
1.1/8	AOSW18	0.984	2.047	10.629	2.220
1.3/16	AOSW19	0.984	2.047	10.629	2.420
1.1/4	AOSW20	0.984	2.047	10.629	2.530
1.5/16	AOSW21	0.984	2.047	10.629	4.070
1.3/8	AOSW22	1.259	2.677	12.283	3.520
1.7/16	AOSW23	1.259	2.677	12.283	3.300
1.1/2	AOSW24	1.259	2.677	12.283	3.890
1.5/8	AOSW26	1.259	2.677	12.283	4.730
1.11/16	AOSW27	1.377	3.228	13.385	4.950
1.3/4	AOSW28	1.377	3.228	13.385	4.840
1.13/16	AOSW29	1.377	3.228	13.385	6.050
1.7/8	AOSW30	1.377	3.228	13.385	6.530
2	AOSW32	1.377	3.228	13.385	6.290
2.1/16	AOSW33	1.496	3.228	14.173	13.180
2.3/16	AOSW35	1.496	3.228	14.173	13.130
2.1/4	AOSW36	1.496	3.228	14.173	11.960
2.5/16	AOSW37	1.496	3.228	14.173	11.550
2.3/8	AOSW38	1.732	4.330	14.960	11.180
2.7/16	AOSW39	1.732	4.330	14.960	16.940
2.1/2	AOSW40	1.732	4.330	14.960	16.940
2.9/16	AOSW41	1.732	4.330	14.960	16.830
2.5/8	AOSW42	1.968	5.000	15.748	16.280
2.3/4	AOSW44	1.968	5.000	15.748	16.104
2.13/16	AOSW45	1.968	5.000	15.748	15.730
2.7/8	AOSW46	1.968	5.000	15.748	15.400
2.15/16	AOSW47	1.968	5.000	15.748	15.400
3	AOSW48	1.968	5.000	15.748	15.140
3.1/8	AOSW50	1.968	5.000	15.748	14.740
3.3/8	AOSW54	2.244	5.984	18.307	23.500
3.1/2	AOSW56	2.244	5.984	18.307	23.430
3.3/4	AOSW60	2.244	5.984	18.307	23.210
3.7/8	AOSW62	2.244	5.984	18.307	22.550
3.15/16	AOSW63	2.244	5.984	18.307	22.220
4.1/8	AOSW66	2.480	7.637	21.259	26.400
4.1/4	AOSW68	2.480	7.637	21.259	26.290
4.5/16	AOSW69	2.480	7.637	21.259	25.830
4.1/2	AOSW72	2.480	7.637	21.259	25.480
4.5/8	AOSW74	2.480	7.637	21.259	24.970
4.3/4	AOSW76	2.480	7.637	21.259	24.420
4.7/8	AOSW78	2.480	7.637	21.259	24.200
5	AOSW80	2.480	7.637	21.259	23.870
5.1/8	AOSW82	2.480	7.637	21.259	23.430



# OPEN JAW SLUGGING WRENCHES

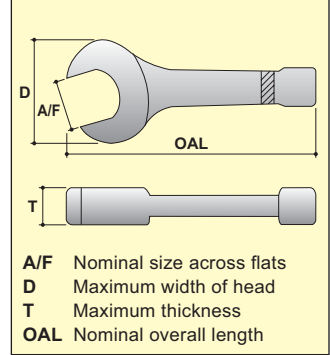

## METRIC SIZES

A / F mm	MODEL NO.	T mm	D mm	OAL mm
24	MOJ24	17	58	175
27	MOJ27	17	58	175
30	MOJ30	18	66	190
32	MOJ32	18	66	190
34	MOJ34	18	73	200
36	MOJ36	20	78	205
38	MOJ38	20	90	225
41	MOJ41	20	90	225
46	MOJ46	22	100	245
50	MOJ50	22	110	270
55	MOJ55	25	120	300
60	MOJ60	25	130	310
65	MOJ65	30	142	340
70	MOJ70	32	156	370
75	MOJ75	32	164	370
80	MOJ80	35	175	395
85	MOJ85	35	175	395
90	MOJ90	40	197	440
95	MOJ95	40	197	440
100	MOJ100	48	230	480
105	MOJ105	48	230	480
110	MOJ110	50	238	505
115	MOJ115	56	250	505
120	MOJ120	56	258	530
130	MOJ130	56	278	560
135	MOJ135	56	278	560
145	MOJ145	62	308	630
150	MOJ150	62	308	630
155	MOJ155	62	308	630
165	MOJ165	70	345	705
170	MOJ170	70	345	705
175	MOJ175	70	345	705
180	MOJ180	70	345	705
200	MOJ200	75	405	760
215	MOJ215	80	425	830
230	MOJ230	80	475	830

## FRACTIONAL SIZES

A / F inch	MODEL NO.	T inch	D inch	OAL inch
15/16	AOJ15	0.669	2.283	6.890
1.1/16	AOJ17	0.669	2.283	6.890
1.1/8	AOJ18	0.708	2.598	7.480
1.1/4	AOJ20	0.708	2.598	7.480
1.5/16	AOJ21	0.708	2.874	7.874
1.3/8	AOJ22	0.708	2.874	7.874
1.7/16	AOJ23	0.787	3.071	8.071
1.1/2	AOJ24	0.787	3.543	8.858
1.5/8	AOJ26	0.787	3.543	8.858
1.11/16	AOJ27	0.787	3.543	8.858
1.13/16	AOJ29	0.866	3.937	9.646
1.7/8	AOJ30	0.866	4.331	10.630
2	AOJ32	0.866	4.331	10.630
2.1/16	AOJ33	0.984	4.724	11.811
2.3/16	AOJ35	0.984	4.724	11.811
2.1/4	AOJ36	0.984	5.118	11.811
2.3/8	AOJ38	0.984	5.118	12.204
2.7/16	AOJ39	1.181	5.590	13.385
2.9/16	AOJ41	1.181	5.590	13.385
2.5/8	AOJ42	1.259	6.141	14.567
2.3/4	AOJ44	1.259	6.141	14.567
2.13/16	AOJ45	1.259	6.457	14.567
2.15/16	AOJ47	1.259	6.457	14.567
3	AOJ48	1.259	6.457	14.567
3.1/8	AOJ50	1.378	6.890	15.551
3.3/8	AOJ51	1.378	6.890	15.551
3.1/2	AOJ56	1.575	7.756	17.323
3.3/4	AOJ60	1.575	7.756	17.323
3.7/8	AOJ62	1.890	9.055	18.898
4.1/8	AOJ66	1.890	9.055	18.898
4.1/4	AOJ68	1.968	9.370	19.882
4.1/2	AOJ72	2.204	9.842	19.882
4.5/8	AOJ74	2.204	10.157	20.866
4.7/8	AOJ78	2.204	10.945	20.866
5	AOJ80	2.204	10.945	22.047
5.1/4	AOJ84	2.204	10.945	22.047
5.3/8	AOJ86	2.204	10.945	22.047
5.5/8	AOJ90	2.441	12.126	24.803
5.3/4	AOJ92	2.441	12.126	24.803
6	AOJ96	2.441	12.126	24.803
6.1/8	AOJ98	2.441	12.126	24.803
6.1/2	AOJ104	2.756	13.582	27.756
6.7/8	AOJ110	2.756	13.582	27.756
7.1/8	AOJ114	2.756	13.582	27.756
7.1/4	AOJ116	2.756	15.157	29.921
7.5/8	AOJ122	2.756	15.157	29.921
7.7/8	AOJ126	2.952	15.945	29.921
8	AOJ128	2.952	15.945	29.921
8.3/8	AOJ134	3.150	16.732	32.677
8.3/4	AOJ140	3.150	17.520	32.677
9.1/8	AOJ146	3.150	18.700	32.677



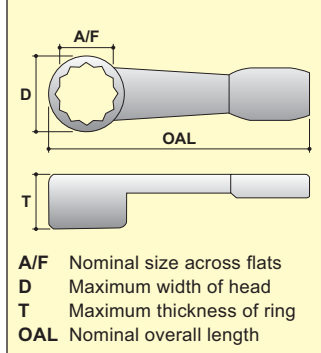

## BOX BI-HEX SLUGGING WRENCHES



### METRIC BIHEXAGON

A / F mm	MODEL NO.	T mm	D mm	OAL mm
24	MBSW24	40.0	47.0	180.0
27	MBSW27	40.0	47.0	180.0
30	MBSW30	40.0	54.0	195.0
32	MBSW32	45.0	54.0	195.0
34	MBSW34	45.0	54.0	195.0
36	MBSW36	45.0	60.0	200.0
38	MBSW38	45.0	66.0	220.0
41	MBSW41	45.0	66.0	220.0
46	MBSW46	50.0	75.0	230.0
50	MBSW50	50.0	80.0	245.0
55	MBSW55	60.0	88.0	260.0
60	MBSW60	60.0	94.0	270.0
65	MBSW65	70.0	104.0	290.0
70	MBSW70	70.0	110.0	320.0
75	MBSW75	80.0	110.0	320.0
80	MBSW80	80.0	126.0	350.0
85	MBSW85	90.0	126.0	350.0
90	MBSW90	90.0	152.0	385.0
95	MBSW95	95.0	152.0	385.0
100	MBSW100	95.0	155.0	415.0
105	MBSW105	105.0	172.0	420.0
110	MBSW110	110.0	172.0	440.0
115	MBSW115	115.0	172.0	440.0
120	MBSW120	120.0	194.0	485.0
130	MBSW130	130.0	205.0	515.0
135	MBSW135	135.0	205.0	515.0
145	MBSW145	145.0	230.0	575.0
150	MBSW150	150.0	230.0	575.0
155	MBSW155	155.0	230.0	575.0
165	MBSW165	165.0	270.0	645.0
170	MBSW170	170.0	270.0	645.0
175	MBSW175	175.0	270.0	645.0
180	MBSW180	180.0	270.0	645.0
200	MBSW200	200.0	295.0	690.0
215	MBSW215	215.0	325.0	735.0
230	MBSW230	230.0	325.0	735.0

### FRACTIONAL BIHEXAGON

A / F inch	MODEL NO.	T inch	D inch	OAL inch
15/16	ABSW15	1.575	1.850	7.086
1.1/16	ABSW17	1.575	1.850	7.086
1.1/8	ABSW18	1.575	2.126	7.677
1.1/4	ABSW20	1.772	2.126	7.677
1.5/16	ABSW21	1.772	2.126	7.677
1.3/8	ABSW22	1.772	2.126	7.677
1.7/16	ABSW23	1.772	2.362	7.874
1.1/2	ABSW24	1.772	2.598	8.661
1.5/8	ABSW26	1.772	2.598	8.661
1.11/16	ABSW27	1.968	2.952	9.055
1.13/16	ABSW29	1.968	2.952	9.055
1.7/8	ABSW30	1.968	2.952	9.055
2	ABSW32	1.968	3.149	9.645
2.1/16	ABSW33	1.968	3.149	9.645
2.3/16	ABSW35	2.362	3.464	10.236
2.1/4	ABSW36	2.362	3.464	10.236
2.3/8	ABSW38	2.362	3.700	10.630
2.7/16	ABSW39	2.362	3.700	10.630
2.9/16	ABSW41	2.756	4.094	11.417
2.5/8	ABSW42	2.756	4.094	11.417
2.3/4	ABSW44	2.756	4.330	12.598
2.13/16	ABSW45	2.756	4.330	12.598
2.15/16	ABSW47	3.149	4.330	12.598
3	ABSW48	3.149	4.330	12.598
3.1/8	ABSW50	3.149	4.961	13.779
3.3/8	ABSW51	3.543	4.961	13.779
3.1/2	ABSW56	3.543	5.984	15.157
3.3/4	ABSW60	3.740	5.984	15.157
3.7/8	ABSW62	3.740	6.102	16.338
4.1/8	ABSW66	4.133	6.772	16.535
4.1/4	ABSW68	4.133	6.772	16.535
4.1/2	ABSW72	4.133	6.772	16.535
4.5/8	ABSW74	4.133	7.637	19.094
4.7/8	ABSW78	4.527	7.637	19.094
5	ABSW80	4.527	8.071	20.276
5.1/4	ABSW84	4.527	8.071	20.276
5.3/8	ABSW86	4.527	8.071	20.276
5.5/8	ABSW90	4.921	9.055	22.638
5.3/4	ABSW92	4.921	9.055	22.638
6	ABSW96	5.314	9.055	22.638
6.1/8	ABSW98	5.314	9.055	22.638
6.1/2	ABSW104	5.905	10.630	25.394
6.7/8	ABSW110	5.905	10.630	25.394
7.1/8	ABSW114	5.905	11.614	27.165
7.1/4	ABSW116	5.905	11.614	27.165
7.5/8	ABSW122	5.905	11.614	27.165
7.7/8	ABSW126	5.905	11.614	27.165
8	ABSW128	5.905	11.614	27.165
8.3/8	ABSW134	6.299	12.795	28.937
8.3/4	ABSW140	6.299	12.795	28.937
9.1/8	ABSW146	6.299	12.795	28.937



# STRUCTURAL WRENCHES

(OFFSET RING TYPE)

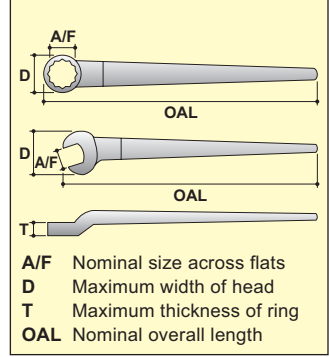

## METRIC BIHEXAGON

A / F mm	MODEL NO.	T mm	D mm	OAL mm	Wt. kg.
24	MOTW24	25	52	430	1.200
27	MOTW27	25	52	430	1.200
30	MOTW30	25	52	430	1.200
32	MOTW32	25	52	430	1.200
34	MOTW34	30	68	530	1.400
36	MOTW36	30	68	530	1.400
38	MOTW38	30	68	530	1.400
41	MOTW41	30	68	530	1.400
46	MOTW46	38	82	650	2.700
50	MOTW50	38	82	650	2.700
55	MOTW55	38	82	650	2.700
60	MOTW60	41	94	710	2.950

## FRACTIONAL BIHEXAGON

A / F inch	MODEL NO.	T inch	D inch	OAL inch	Wt. lbs.
15/16	AOTW15	0.984	2.047	16.929	2.640
1.1/16	AOTW17	0.984	2.047	16.929	2.640
1.1/8	AOTW18	0.984	2.047	16.929	2.640
1.1/4	AOTW20	0.984	2.047	16.929	2.640
1.5/16	AOTW21	0.984	2.047	16.929	2.640
1.3/8	AOTW22	1.102	2.677	16.929	3.080
1.7/16	AOTW23	1.102	2.677	20.866	3.080
1.1/2	AOTW24	1.181	2.677	20.866	3.080
1.5/8	AOTW26	1.496	3.228	25.590	3.080
1.11/16	AOTW27	1.496	3.228	25.590	5.940
1.13/16	AOTW29	1.496	3.228	25.590	5.940
1.7/8	AOTW30	1.220	2.952	22.834	5.940
2	AOTW32	1.377	3.149	24.606	5.940
2.1/16	AOTW33	1.377	3.149	24.606	5.940
2.3/16	AOTW35	1.377	3.464	25.984	5.940
2.1/4	AOTW36	1.377	3.464	25.984	5.940
2.3/8	AOTW38	1.614	3.700	27.952	6.380
2.7/16	AOTW39	1.614	3.700	27.952	6.380

# STRUCTURAL WRENCHES

(OFFSET OPEN JAW TYPE)



## METRIC SIZES

A / F mm	MODEL NO.	T mm	D mm	OAL mm	Wt. kg.
24	MOTOJ24	25	52	430	1.200
27	MOTOJ27	25	52	430	1.200
30	MOTOJ30	25	52	430	1.200
32	MOTOJ32	25	52	430	1.200
34	MOTOJ34	30	68	530	1.400
36	MOTOJ36	30	68	530	1.400
38	MOTOJ38	30	68	530	1.400
41	MOTOJ41	30	68	530	1.400
46	MOTOJ46	38	82	650	2.700
50	MOTOJ50	38	82	650	2.700
55	MOTOJ55	38	82	650	2.700
60	MOTOJ60	41	94	710	2.950

## FRACTIONAL SIZES

A / F inch	MODEL NO.	T inch	D inch	OAL inch	Wt. lbs.
15/16	AOTOJ15	0.984	2.047	16.929	2.640
1.1/16	AOTOJ17	0.984	2.047	16.929	2.640
1.1/8	AOTOJ18	0.984	2.047	16.929	2.640
1.1/4	AOTOJ20	0.984	2.047	16.929	2.640
1.5/16	AOTOJ21	0.984	2.047	20.870	2.640
1.3/8	AOTOJ22	1.102	2.670	16.929	3.080
1.7/16	AOTOJ23	1.102	2.670	20.866	3.080
1.1/2	AOTOJ24	1.102	2.670	20.866	3.080
1.5/8	AOTOJ26	1.102	2.670	25.590	3.080
1.11/16	AOTOJ27	1.490	3.228	25.590	5.940
1.13/16	AOTOJ29	1.490	3.228	25.590	5.940
1.7/8	AOTOJ30	1.490	3.228	22.834	5.940
2	AOTOJ32	1.490	3.228	24.606	5.940
2.1/16	AOTOJ33	1.490	3.228	24.606	5.940
2.3/16	AOTOJ35	1.490	3.228	25.984	5.940
2.1/4	AOTOJ36	1.490	3.228	25.984	5.940
2.3/8	AOTOJ38	1.614	3.700	27.952	6.380
2.7/16	AOTOJ39	1.614	3.700	27.952	6.380

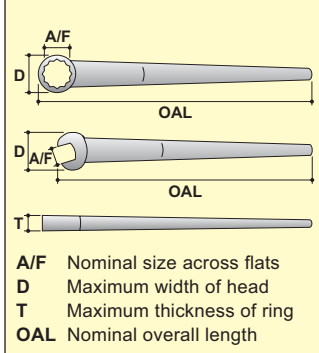

## STRUCTURAL WRENCHES

(FLAT RING TYPE)



### METRIC BIHEXAGON



A / F mm	MODEL NO.	T mm	D mm	OAL mm	Wt. kg.
24	MTW24	17	47	375	0.760
27	MTW27	17	47	375	0.760
30	MTW30	18	54	375	0.920
32	MTW32	18	54	430	0.920
34	MTW34	18	54	430	0.950
36	MTW36	20	60	530	0.950
38	MTW38	22	66	530	1.650
41	MTW41	22	66	530	1.850
46	MTW46	25	75	580	1.850
50	MTW50	25	80	625	2.250
55	MTW55	26	88	660	2.250
60	MTW60	28	94	710	2.250

### FRACTIONAL BIHEXAGON



A / F inch	MODEL NO.	T inch	D inch	OAL inch	Wt. lbs.
15/16	ATW15	0.669	1.850	14.763	1.670
1.1/16	ATW17	0.669	1.850	14.763	1.670
1.1/8	ATW18	0.708	2.125	14.763	2.000
1.1/4	ATW20	0.708	2.125	16.929	2.000
1.5/16	ATW21	0.708	2.125	16.929	2.150
1.3/8	ATW22	0.708	2.125	16.929	2.150
1.7/16	ATW23	0.787	2.362	20.866	3.520
1.1/2	ATW24	0.866	2.598	20.866	4.100
1.5/8	ATW26	0.866	2.598	20.866	4.100
1.11/16	ATW27	0.984	2.952	20.866	4.950
1.13/16	ATW29	0.984	2.952	22.834	4.950
1.7/8	ATW30	0.984	2.952	22.834	4.950
2	ATW32	0.984	3.149	24.606	5.610
2.1/16	ATW33	0.984	3.149	24.606	5.610
2.3/16	ATW35	1.023	3.464	25.984	6.000
2.1/4	ATW36	1.023	3.464	25.984	6.000
2.3/8	ATW38	1.102	3.700	27.952	6.270
2.7/16	ATW39	1.102	3.700	27.952	6.270

## STRUCTURAL WRENCHES

(FLAT OPEN JAW TYPE)



### METRIC SIZES

A / F mm	MODEL NO.	T mm	D mm	OAL mm	Wt. kg.
24	MTOJ24	17	58	375	0.760
27	MTOJ27	17	58	375	0.760
30	MTOJ30	18	66	375	0.920
32	MTOJ32	18	66	430	0.920
34	MTOJ34	18	73	430	0.950
36	MTOJ36	20	78	530	0.950
38	MTOJ38	20	90	530	1.650
41	MTOJ41	20	90	530	1.850
46	MTOJ46	22	100	580	1.850
50	MTOJ50	22	110	625	2.250
55	MTOJ55	25	120	660	2.250
60	MTOJ60	25	130	710	2.250

### FRACTIONAL SIZES

A / F inch	MODEL NO.	T inch	D inch	OAL inch	Wt. lbs.
15/16	ATOJ15	0.669	2.283	14.763	1.670
1.1/16	ATOJ17	0.669	2.283	14.763	1.670
1.1/8	ATOJ18	0.708	2.598	14.763	2.000
1.1/4	ATOJ20	0.708	2.874	16.929	2.000
1.5/16	ATOJ21	0.708	2.874	16.929	2.150
1.3/8	ATOJ22	0.708	2.874	16.929	2.150
1.7/16	ATOJ23	0.787	3.070	20.866	3.520
1.1/2	ATOJ24	0.787	3.543	20.866	4.100
1.5/8	ATOJ26	0.787	3.543	20.866	4.100
1.11/16	ATOJ27	0.787	3.543	20.866	4.950
1.13/16	ATOJ29	0.866	3.937	22.834	4.950
1.7/8	ATOJ30	0.866	4.330	22.834	4.950
2	ATOJ32	0.866	4.330	24.606	5.610
2.1/16	ATOJ33	0.984	4.724	24.606	5.610
2.3/16	ATOJ35	0.984	4.724	25.984	6.000
2.1/4	ATOJ36	0.984	5.118	25.984	6.000
2.3/8	ATOJ38	0.984	5.118	27.952	6.270
2.7/16	ATOJ39	1.181	5.590	27.952	6.270

# INSERT SOCKETS

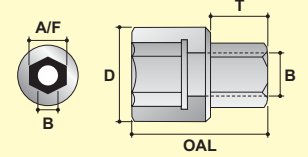

**A/F** Nominal size across flats  
**D** Max. outside dia. socket end  
**B** Bolt clearance hole  
**OAL** Nominal overall length  
**T** Hex bit length



## METRIC HEXAGON

A / F mm	MODEL NO.	T mm	B mm	D mm	OAL mm
24	MIS24	15.0	16	39.0	41.0
27	MIS27	16.0	20	43.0	43.0
30	MIS30	17.0	22	47.0	46.0
32	MIS32	18.0	24	49.0	49.0
34	MIS34	19.0	24	62.0	51.0
36	MIS36	20.0	26	54.0	53.0
38	MIS38	21.0	28	57.0	55.0
41	MIS41	23.0	29	61.0	61.0
46	MIS46	25.0	33	67.0	67.0
50	MIS50	27.0	36	74.0	74.0
55	MIS55	29.0	38	80.0	80.0
60	MIS60	32.0	40	86.0	86.0
65	MIS65	34.0	45	92.0	93.0
70	MIS70	35.0	48	99.0	99.0
75	MIS75	39.0	52	105.0	103.0
80	MIS80	40.0	55	111.0	108.0
85	MIS85	42.0	60	117.0	112.0
90	MIS90	45.0	64	125.0	119.0
95	MIS95	48.0	68	131.0	125.0
100	MIS100	50.0	72	137.0	130.0
105	MIS105	51.0	76	143.0	134.0
110	MIS110	53.0	80	150.0	141.0
115	MIS115	54.0	85	156.0	147.0
120	MIS120	57.0	90	162.0	154.0
130	MIS130	60.0	95	175.0	161.0
135	MIS135	64.0	100	181.0	168.0
145	MIS145	68.0	105	194.0	175.0

## FRACTIONAL HEXAGON

A / F inch	MODEL NO.	T inch	B inch	D inch	OAL inch
15/16	AIS15	0.591	0.629	1.535	1.610
1.1/16	AIS16	0.630	0.787	1.693	1.690
1.1/8	AIS18	0.669	0.864	1.850	1.810
1.1/4	AIS20	0.709	0.995	1.929	1.930
1.5/16	AIS21	0.748	0.945	2.047	2.010
1.3/8	AIS22	0.787	1.000	2.126	2.090
1.7/16	AIS23	0.787	1.000	2.126	2.090
1.1/2	AIS24	0.827	1.102	2.244	2.170
1.5/8	AIS26	0.906	1.181	2.402	2.400
1.11/16	AIS27	0.984	1.181	2.522	2.640
1.13/16	AIS29	0.984	1.299	2.638	2.640
1.7/8	AIS30	1.065	1.299	2.750	2.910
2	AIS32	1.063	1.417	2.913	2.910
2.1/16	AIS33	1.142	1.417	3.000	3.150
2.3/16	AIS35	1.142	1.496	3.150	3.150
2.7/16	AIS39	1.260	1.600	3.485	3.390
2.9/16	AIS41	1.339	1.770	3.622	3.660
2.5/8	AIS42	1.339	1.700	3.720	3.660
2.3/4	AIS44	1.378	1.890	3.898	3.900
2.13/16	AIS45	1.378	1.950	3.998	3.900
2.15/16	AIS47	1.535	2.000	4.134	4.060
3	AIS48	1.535	2.100	4.235	4.060
3.1/8	AIS50	1.575	2.150	4.370	4.250
3.3/8	AIS54	1.654	2.450	4.720	4.410
3.1/2	AIS56	1.772	2.450	4.921	4.690
3.3/4	AIS60	1.890	2.700	5.157	4.920
3.7/8	AIS62	1.969	2.700	5.394	5.120
4.1/8	AIS66	2.008	2.900	5.630	5.280
4.1/4	AIS68	2.087	3.000	6.906	5.550
4.1/2	AIS72	2.160	3.000	6.142	5.790
4.5/8	AIS74	2.224	3.196	6.378	6.060
4.7/8	AIS78	2.362	3.446	6.750	6.340
5	AIS80	2.362	3.446	6.820	6.340
5.1/4	AIS84	2.520	3.725	7.130	6.610
5.3/8	AIS86	2.520	3.735	7.250	6.610
5.5/8	AIS90	2.667	3.885	7.640	6.890
5.3/4	AIS92	2.677	3.985	7.780	6.890

**Note:** Insert sockets are also made to different female hex for any one suitable male hex as per requirement.



# TURBINE TOOLS

NOMINAL SIZE	MODEL NO.	B inch	D inch	OAL inch	Wt. Kg.
2.1/4	141B8001	2.1/8	3.1/2	3.5/8	2.530
2.1/2	141B8002	2.3/8	3.7/8	3.7/8	3.300
2.3/4	141B8003	2.5/8	4.1/4	4.3/8	6.200
3	141B8004	1.7/8	4.5/8	4.3/8	6.800
3.1/2	141B8005	1.3/8	5.3/8	5.3/8	10.800
4	141B8006	1.7/8	6.1/8	5.7/8	15.650
4.1/2	141B8007	4.3/8	6.7/8	6.5/8	18.890
5	141B8008	2.1/8	7.5/8	7.1/8	29.000
5.1/2	141B8009	3.5/8	8.3/8	8.1/8	38.500
6	141B8010	3.7/8	9.1/4	8.5/8	50.000
2.1/2	141B8011	2.3/8	3.7/8	18	12.500
2.1/2	141B8012	2.3/8	3.7/8	24	18.900
3.3/4	141B8013	1.13/16	5.3/4	5.5/8	15.000
4	141B8014	1.7/8	6.1/8	23.5/8	79.000
7	141B8015	4.7/8	10.5/8	10	8.600
1.3/4	141B8016	1.5/8	2.3/4	2.5/8	1.150
2	141B8017	1.7/8	3.1/8	2.7/8	1.630
4	141B8018	3.7/8	6.1/8	23.5/8	52.000
4	141B8019	3.7/8	6.1/8	5.7/8	11.840
3.1/2	141B8020	3.3/8	5.3/8	5.3/8	8.500

## SPANNER WRENCH SOCKET

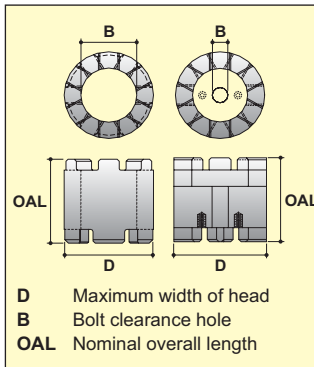

A / F inch	MODEL NO.	T inch	D inch	OAL inch	Wt. Kg.
1.11/16	M968914	7/8	2.5/8	2.3/8	0.720
1.7/8	M968915	1	2.5/8	2.5/8	0.960
2.1/16	M968916	1.1/16	2.7/8	2.15/16	1.325
2.1/4	M968917	1.1/8	3.1/8	3.1/8	1.640
2.7/16	M968918	1.1/4	3.5/8	3.5/8	2.000
2.5/8	M968919	1.5/16	3.5/8	3.9/16	2.480
2.13/16	M968920	1.3/8	3.7/8	3.3/4	2.850
3	M968921	1.1/2	4.1/8	4	3.240
3.3/8	M968922	1.5/8	4.5/8	4.3/8	3.720
3.3/4	M968923	1.7/8	5.1/8	4.7/8	6.310
4.1/8	M968924	2	5.3/4	5.1/4	8.500
4.1/2	M968925	2.1/8	6.1/8	5.3/4	10.710
4.7/8	M968926	2.3/8	6.5/8	6.1/4	12.800
5.1/4	M968927	2.1/2	7.1/8	6.5/8	16.000
5.5/8	M968928	2.5/8	7.3/4	7.1/8	20.000
6	M968929	2.3/4	8.1/8	7.1/2	24.000
6.3/4	M968930	3	9.1/8	8.3/8	29.000
7.1/2	M968931	3.1/2	10.1/8	9.1/2	34.000

## WRENCH SOCKET

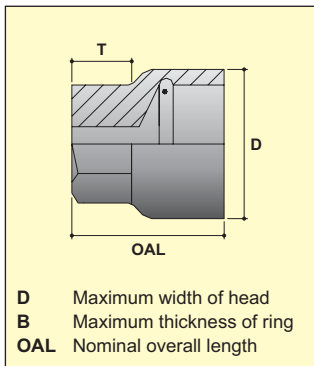

NOMINAL SIZE	MODEL NO.	B inch	D inch	OAL inch	Wt. Kg.
2.3/4	141B8101	2.5/8	4.1/4	11.1/8	3.200
3	141B8102	2.7/8	4.5/8	12.5/16	4.000
3.1/2	141B8103	3.3/8	5.3/8	13.7/8	6.500
4	141B8104	3.7/8	6.1/8	15.1/16	8.000
4.1/2	141B8105	4.3/8	6.7/8	16.7/16	10.000
5	141B8106	4.7/8	7.5/8	18.1/18	13.500
5.1/2	141B8107	5.3/8	8.3/8	19.3/16	15.000
6	141B8108	5.7/8	9.1/4	20.5/8	19.000
2.1/4	141B8109	2.1/8	3.1/2	10.1/8	2.600
2.1/2	141B8110	2.3/8	3.7/8	10.1/4	3.100
3.3/4	141B8111	3.13/16	5.3/4	14.3/8	7.800
1.3/4	141B8112	1.5/8	2.3/4	8.13/16	2.100
3.1/8	141B8113	1.7/8	3.1/8	10.1/2	2.500
10.5/8	141B8114	6.7/8	10.5/8	22.5/16	30.000

## SPANNER SLEDGING WRENCH

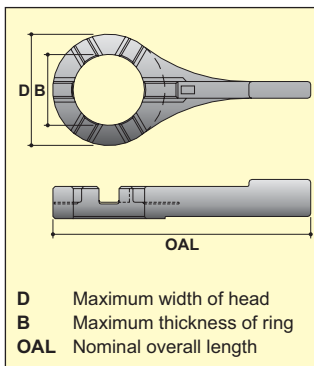

**POWERMASTER AMERICA LLC.**

26, Russell Park Road, Syosset, New York 11791.

Phone : +1 516.503.5294

Website: [www.powermasteramerica.com](http://www.powermasteramerica.com) Email: [sales@powermasteramerica.com](mailto:sales@powermasteramerica.com)